

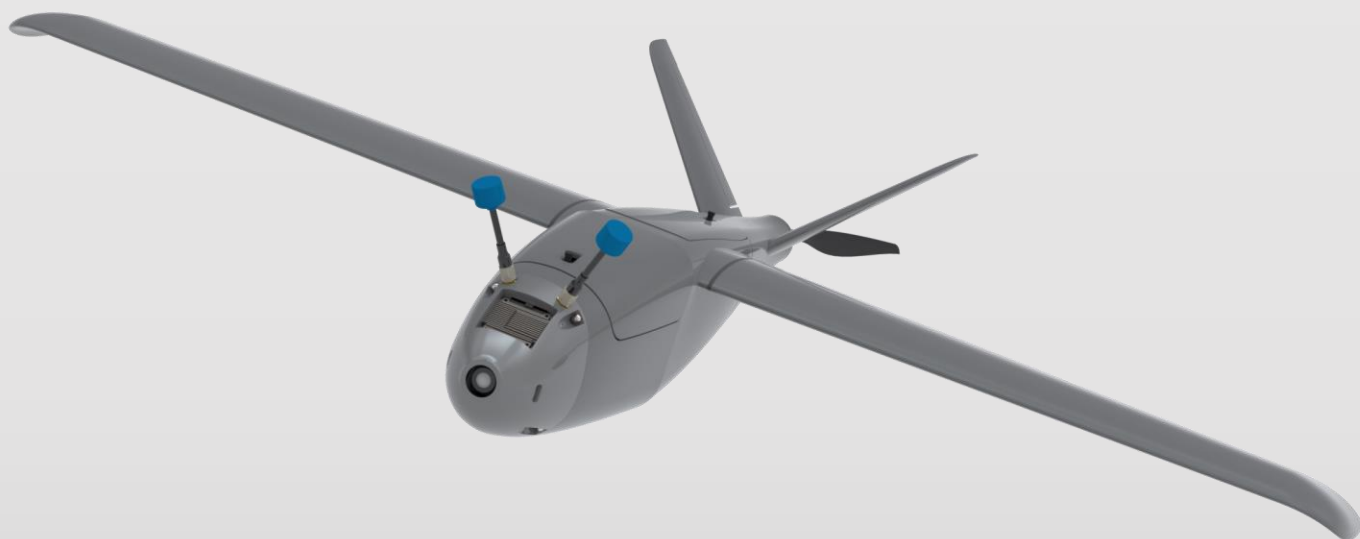

picoTALON



USER MANUAL

V.1

© 2023 Flightory by Szymon Wójcik All rights reserved.

Socials



Join Flightory Tech group on Facebook and create community with us. Share progress of your builds. Any suggestions or questions welcome.

www.facebook.com/groups/flightory



Join our Discord server as well, where the discussions are organized by topics, and the interaction between users is lively.

<https://discord.gg/GPMgDZ3Cvx>



Follow us on Instagram for regular updates and fresh content

www.instagram.com/flightory



General Aircraft Data

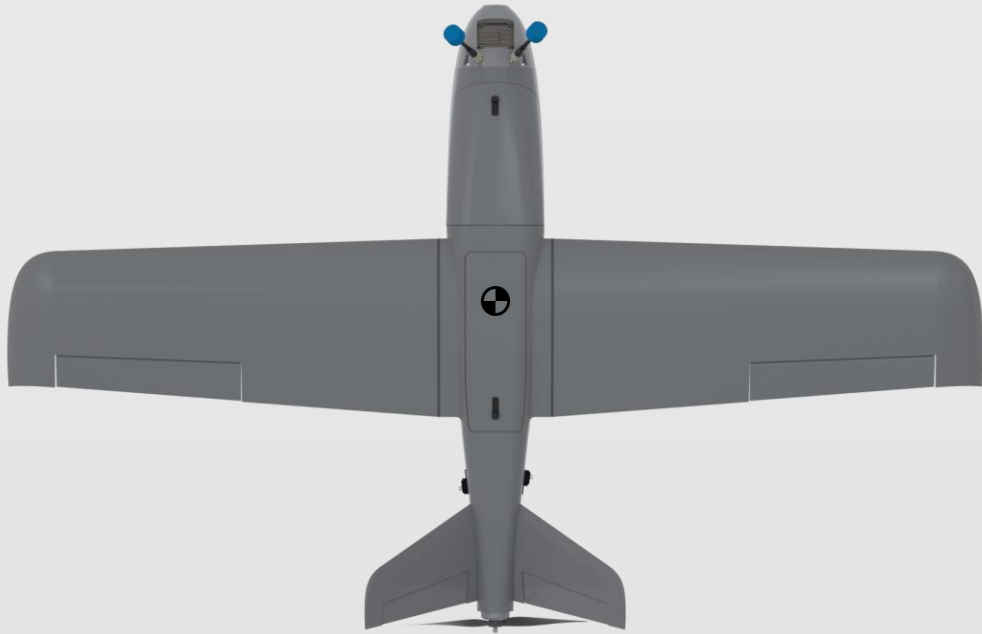

General data	
Wingspan	900mm
Wing area	13 dm ²
Lenght	570mm
Center of Gravity	44mm from leading edge
AUW	800g (max 1500g)
Optimal Cruise Speed	55-75 km/h
Airfoil	Eppler E205
Root Chord	169mm
MAC	145mm
Aspect Ratio	6.2
Wing load	60 -115 g / dm ²

CFD Analysis

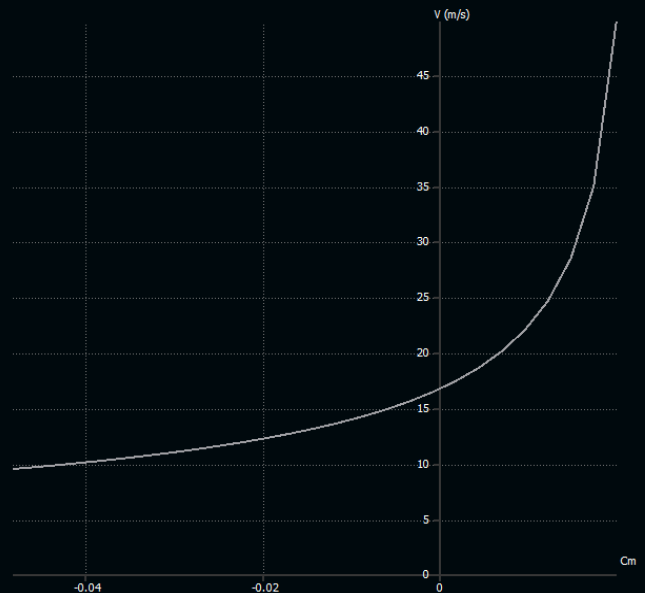
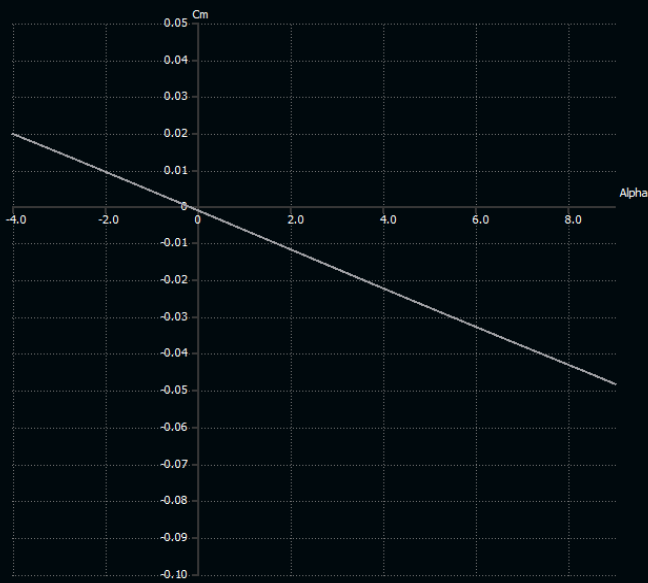
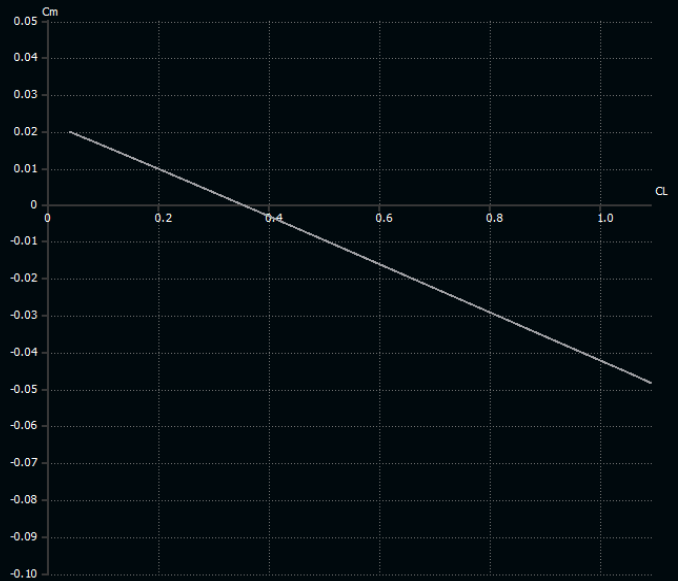
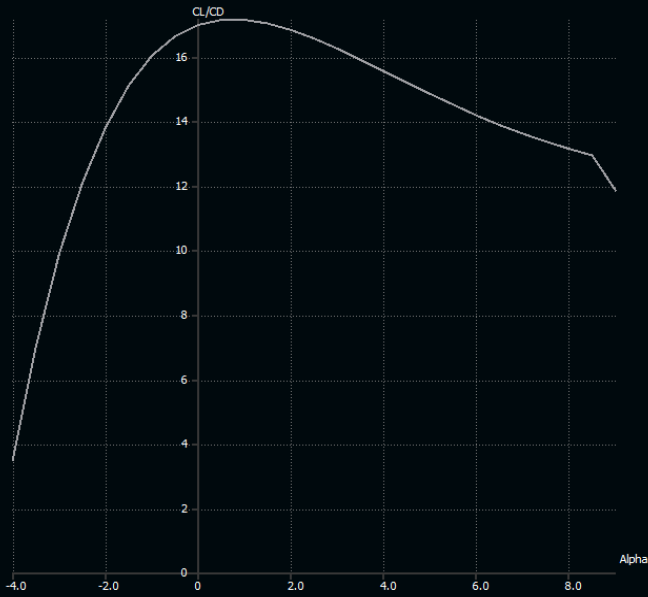

Geometry is designed to provide the best possible characteristics. During preliminary testing, a number of airfoils were checked and Eppler E205 was finally selected. The aircraft's longitudinal stability is ensured by a fair margin. With the center of gravity properly adjusted, for horizontal flight at zero angle of attack, there is no pitch moment, which was also confirmed in test flights. Optimal angles of attack are in the range of 0 to 2 degrees, the cruising speeds providing the greatest flight time are in the range of 55 to 75 km/h/.

Exploded view

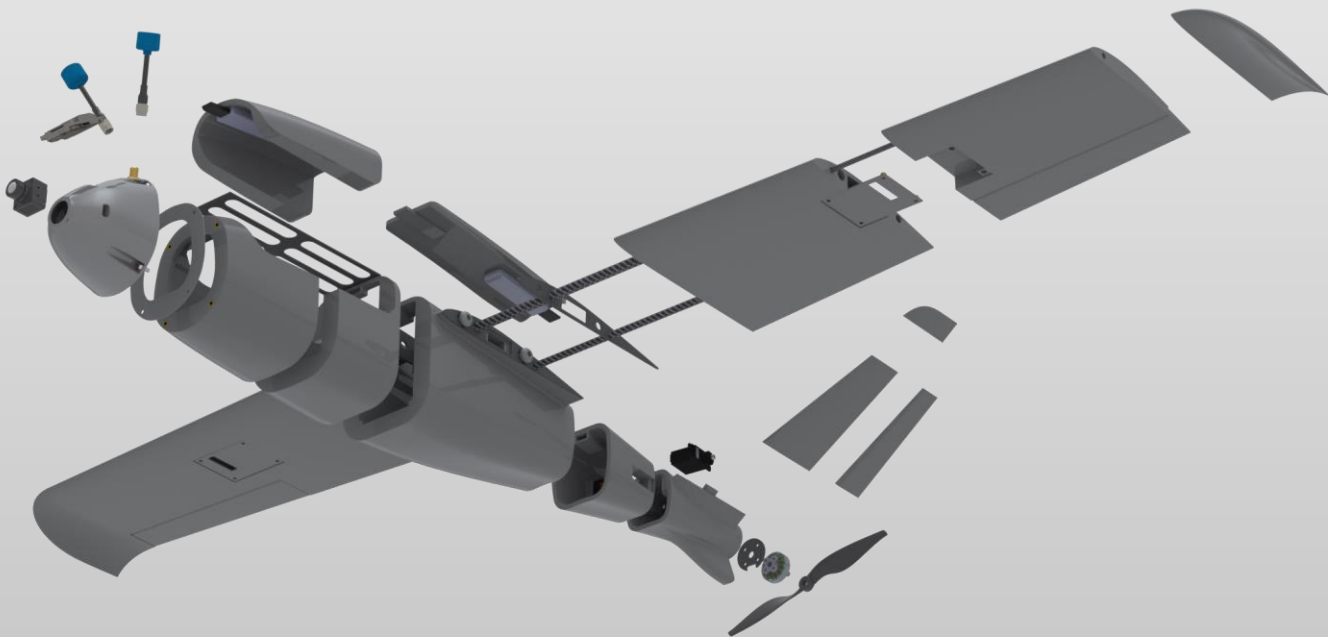
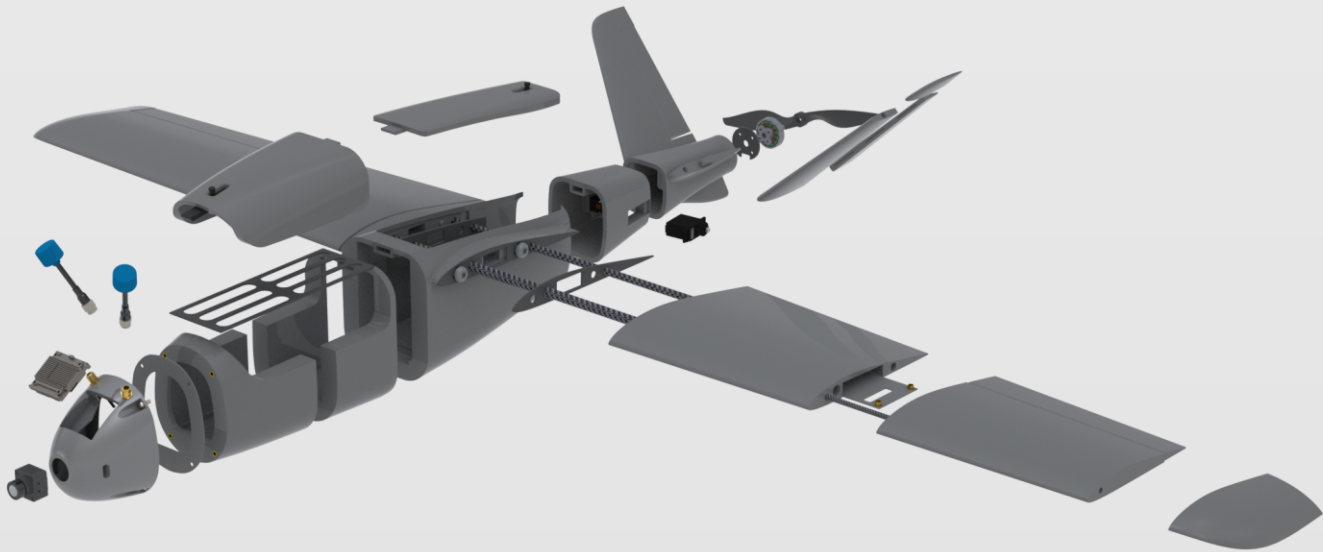

Print Settings

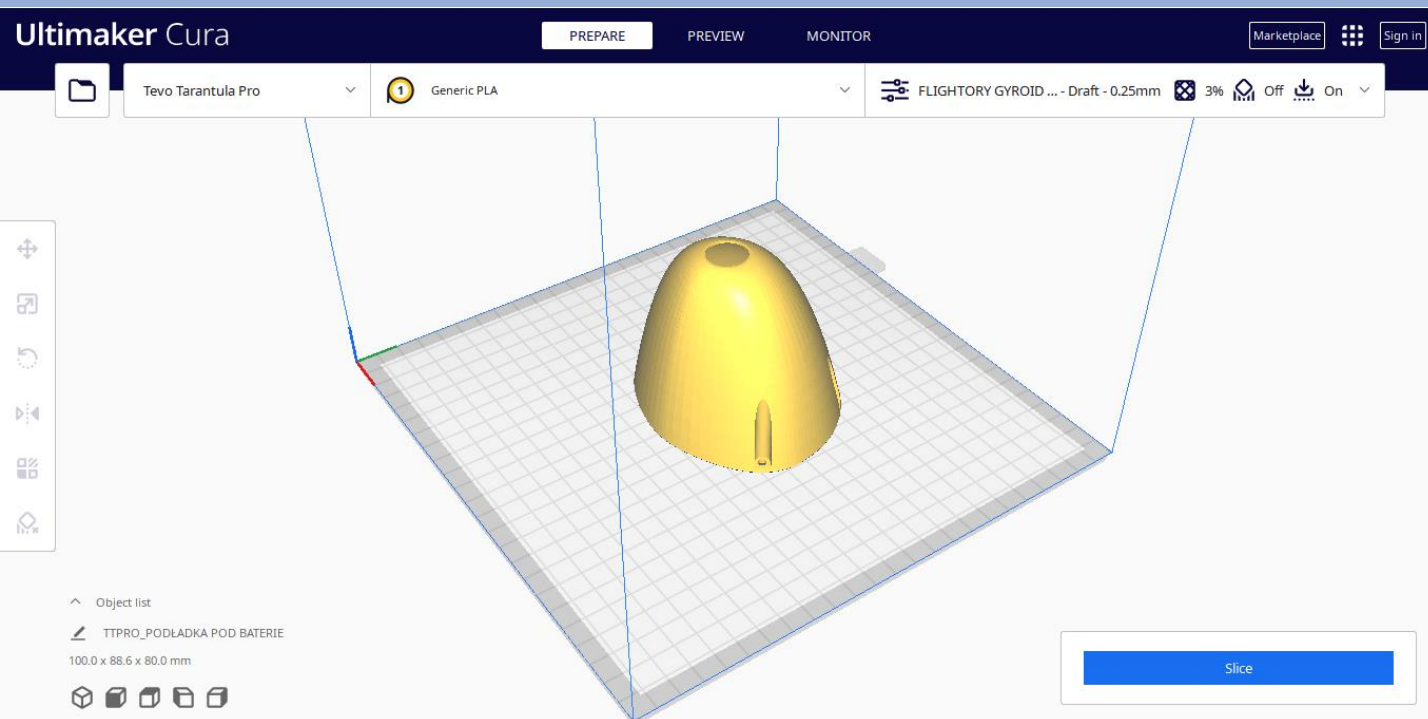

Slicer software you need to use is Ultimater Cura. All elements from **LW-PLA** are best printed with ready-made settings prepared in a profile that you can download. Settings are prepared a standard 0.4mm nozzle. Download link is available on the Stork product page and on Flightory Blog. **Infill in this profile is set to 6%. For this project I recommend changing it to 3%, max 4%. This is sufficient filling**

Main features of slicer LW-PLA profile

- layer height: 0,25 mm
- single wall 0,4mm thickness
- 3% Gyroid infill.
- Temperature: 235 degrees,
- flow 60%
- fan speed: 0%

The rest of the detailed settings are saved in the profile.

To print hard **PLA** or **PET-G** parts, use a default profile in CURA called **Draft**. **Layer height is 0.2 mm, infill is 20% Grid pattern**. Set the temperature around **220 degrees**. You can fine-tune these parameters to suit your needs and your printer.

Print Settings

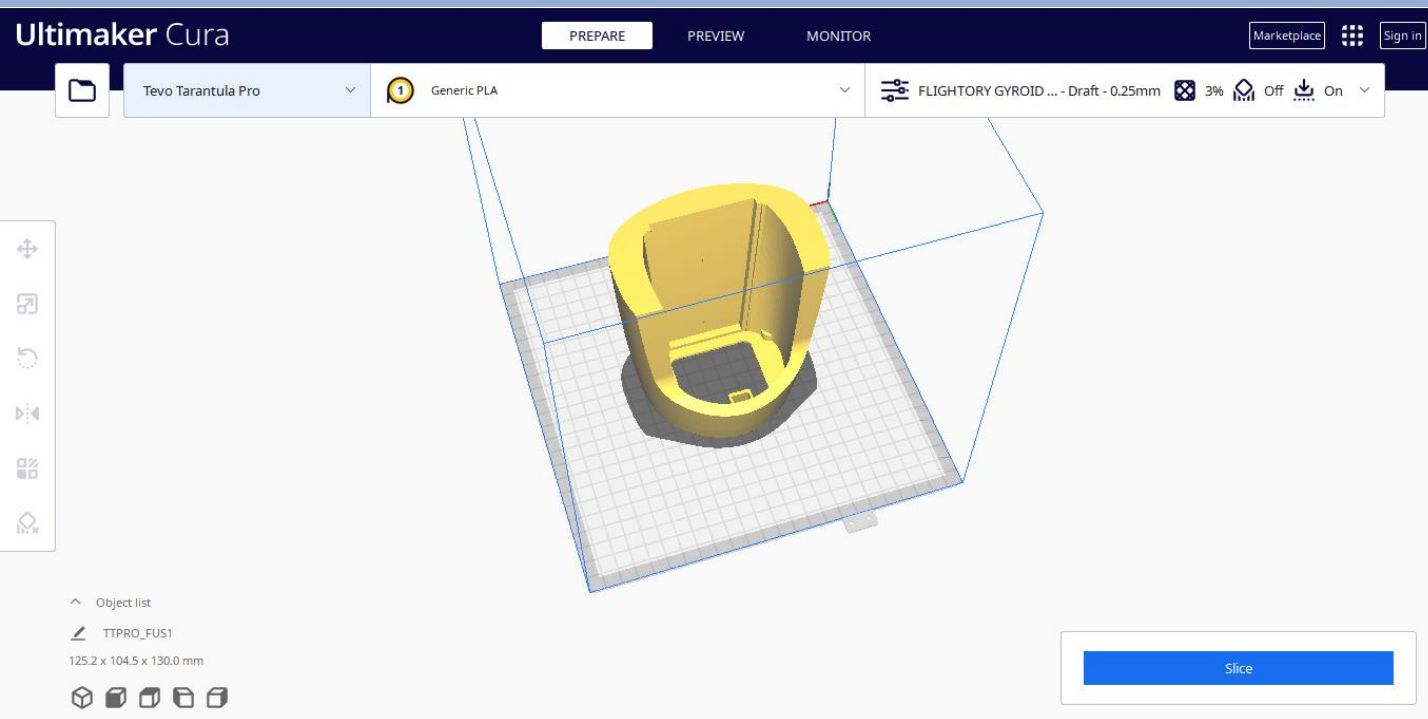

All parts are suitable for printing on any standard printer with a small working area. I printed all parts on a 200 x 200mm area.

All elements can be printed without supports, but your printer may have a problem with some horizontal surfaces in some places. Depending on the effects, you may then consider turning on supports for some elements and cleaning the printed elements afterwards.

Reccomended RC Equipment

Reccomended electronics	
Motor	T-Motor F90 1300KV or similar size
Propeller	7x4, 7x5, 7x6
Flight Controller	Speedybee F405 Wing / Matek F405 WMN or any similar
GPS	Matek M10Q or similar GPS with compass
Servos	2x Corona 929MG Metal Gear + 2x Corona CS239MG Slim Wing
ESC	40A
Battery	Li-on 21700 4S1P 5000mAh or any around 300g
Receiver	Matek R24-D ELRS
VTX	Digital or analog VTX

Required accessories

ITEM	QUANTITY
8x500mm Carbon Tube (MAIN SPAR)	1
6x490mm Carbon Tube (SECOND SPAR)	1
4x220mm Carbon Tube (SPAR)	2
4x130mm Carbon Tube (VTAIL SPAR)	2
Thin CA Glue	20g tube
CA Activator	1 (optional but useful)
M3 Threaded Insert (Outer \varnothing 5mm, height 5mm)	16
M3 screw	16
Plastic M6x45mm screw	4
M6 nut	4
LW-PLA	1 roll
PLA	Small amount
Polyester hinge 20x25mm	12
Pen spring	2
Velcro strap	2
Servo extension cable	2 (optional)

PARTS LIST - FUSELAGE

PART	MATERIAL
FUS 1	LW-PLA
FUS 2	LW-PLA
FUS 3	LW-PLA
FUS 4	LW-PLA
FUS 5	LW-PLA
FUS 6 (default)	LW-PLA
FUS 6 (wide motor mount)	LW-PLA
FUS 6 (34mm wide mount)	LW-PLA
HATCH FRONT 1	LW-PLA
HATCH FRONT 2	LW-PLA
HATCH MIDDLE 1	LW-PLA
HATCH MIDDLE 2	LW-PLA
NOSE WALKSNAIL	PLA
NOSE CLEAN	PLA
NOSE REINFORCEMENT	PLA
BATTERY PAD	PLA
INNER REINFORCEMENT (print 2)	PLA
FUS ROOT (print 2)	PLA
FIREWALL (3 variants)	PLA
LOCK 1 (print 2)	PLA
LOCK 2 (print 2)	PLA

PARTS LIST - WINGS

PART	MATERIAL
WING 1R	LW-PLA
WING 2R	LW-PLA
WINGTIP R	LW-PLA
AIL R	LW-PLA
WING 1L	LW-PLA
WING 2L	LW-PLA
WINGTIP L	LW-PLA
AIL L	LW-PLA
SERVO COVER R	PLA
SERVO COVER L	PLA
WING ROOT (print 2)	PLA

PARTS LIST - VTAIL

PART	MATERIAL
V TAIL 1R	LW-PLA
V TAIL 2R	LW-PLA
V TAIL 1L	LW-PLA
V TAIL 2L	LW-PLA
V TAIL RUDDER R	PLA / LW-PLA
V TAIL RUDDER L	PLA / LW-PLA

STEP FILES LIST

PART
AILERON
RUDDER
SERVO COVER
HATCH FRONT
HATCH MIDDLE
NOSE CLEAN

Fuselage assembly

Before starting build, choose an option for mounting the motor. There are 3 options to choose from.

First way is to directly mount a T-Motor F90 or other motor with a screw spacing of 19mm. In this case, it is necessary to bolt from the center of fuselage. If you choose this option, I recommend adjusting the screws at the very beginning, so that later only tighten them. Take **FUS 6** and **FIREWALL**. Paste the firewall and insert the screws into the holes from the inside of the fuselage

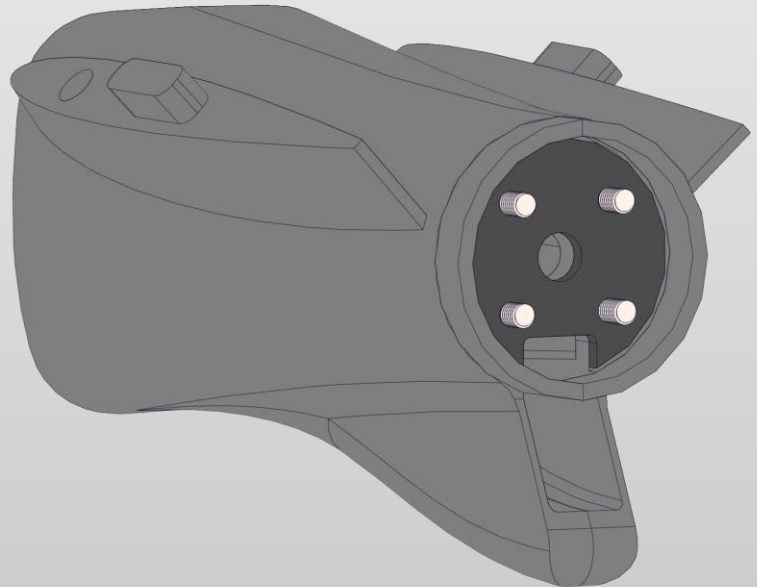
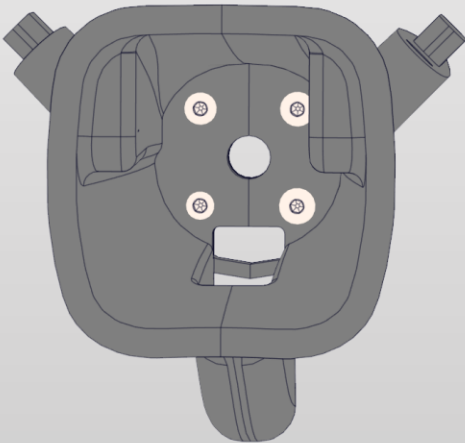

Fuselage assembly

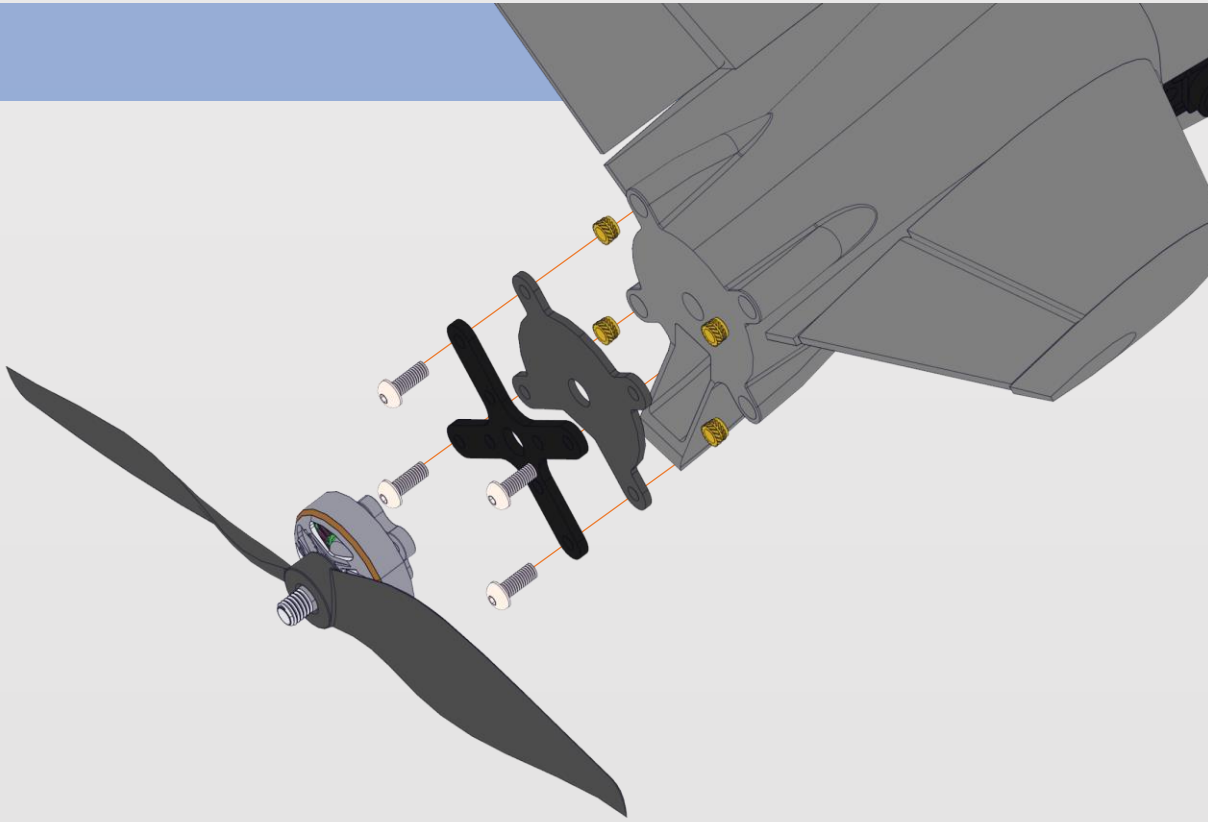

Other options do not require bolting from the center of the fuselage. If you are using T-Motor F90 or a similar motor, a modified **FUS 6** file is prepared for this solution. It has a widened mount, a different firewall and an additional bed that will allow you to bolt this motor from the outside. In the picture you can see a diagram of this mount.

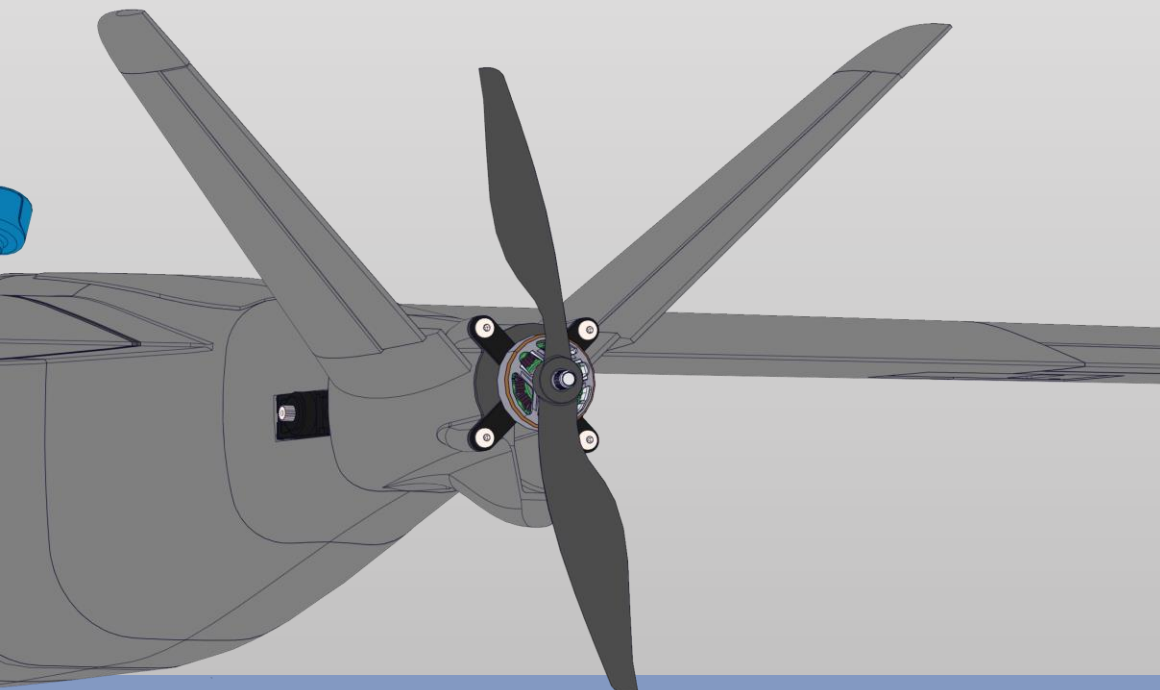

Fuselage assembly

Third option will allow the installation of a larger motor, with a 34mm bolt spacing bed. This is a common size for many motors, e.g. 2216. Mounting looks very similar to the previous case, separate files marked in the folder.

I recommend using the F90 motor, which with its low weight and high performance, is ideal for a model of this size. However, if you want to use a larger motor, you can use this solution.

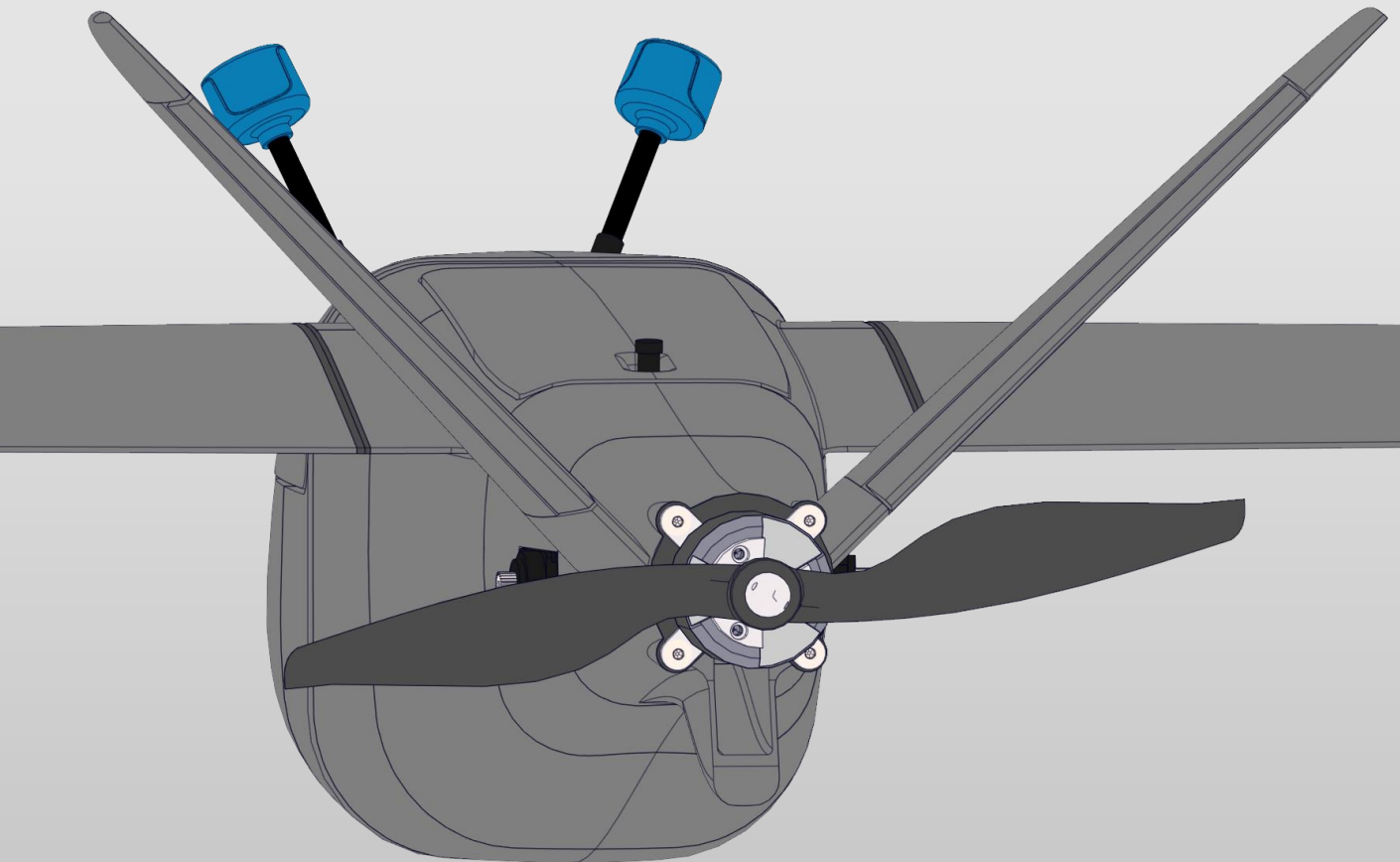

Nose variants

The nose is completely removable and has the ability to accommodate FPV camera, VTX and antennas. A version adapted for Walksnail is prepared. A "clean" version is also available with mounting of a standard FPV camera, but without VTX mounting. This version is also available in STEP format. Anyone wishing to modify the nose to suit their own needs will be able to do so more easily. Since the nose is detachable, you can also design your solution from scratch.



Several thin supports are designed in the nose, which should be removed after printing.

STEP files

Several other files have also been prepared in STEP format to allow easier editing. Included flaps, ailerons, rudders, servo covers and nose. If you want to add your modifications, it will be simpler with these files than editing STL.

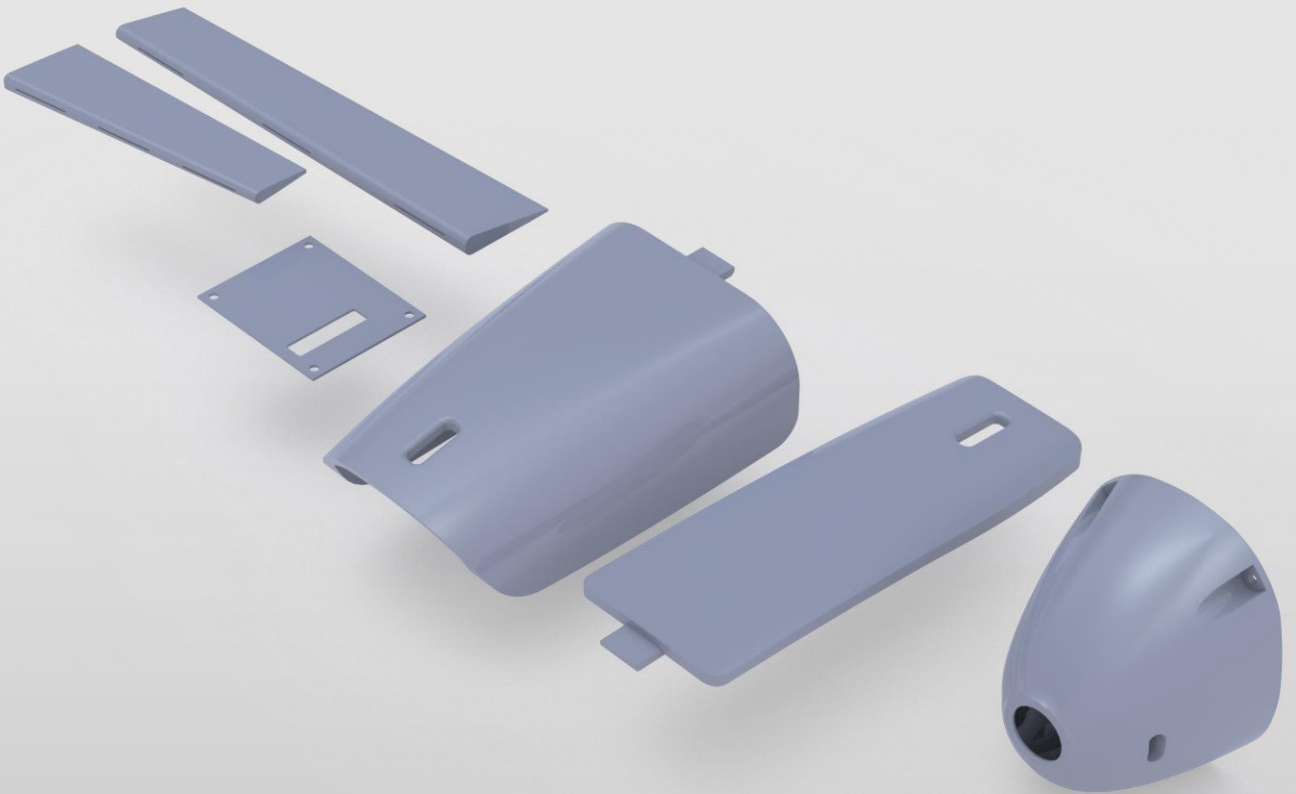

You can find these files in folders labeled STEP

Fuselage assembly

Prepare all fuselage segments. Before gluing, you can gently sand the surface of all elements, especially the gluing surfaces.

It's best to use **thick CA glue**.

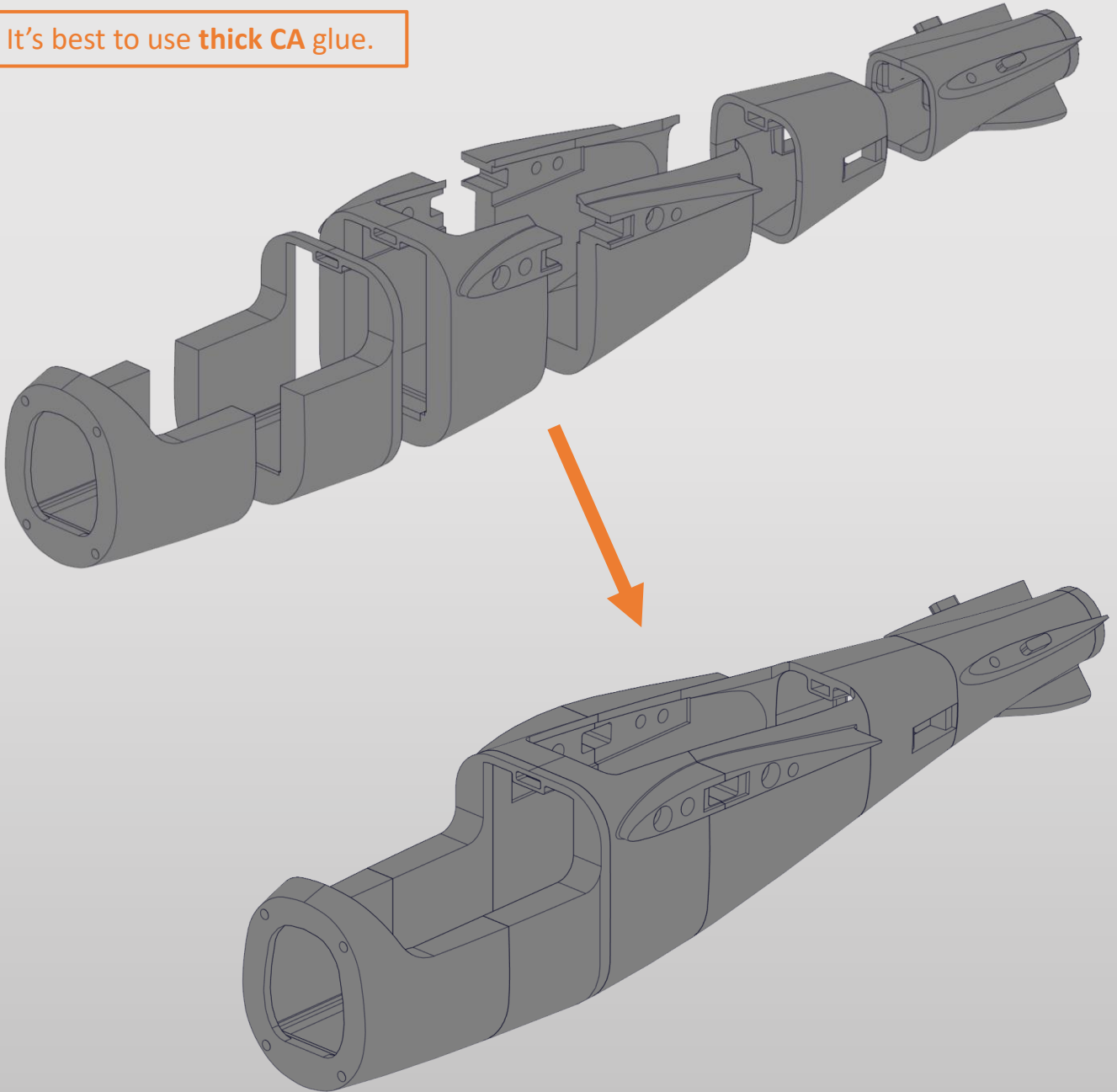

Fuselage assembly

Prepare parts printed from PLA or other hard material. Take the **BATTERY PAD** and paste it in the designated place in the front of the fuselage.

It's best to use **thick CA glue**.

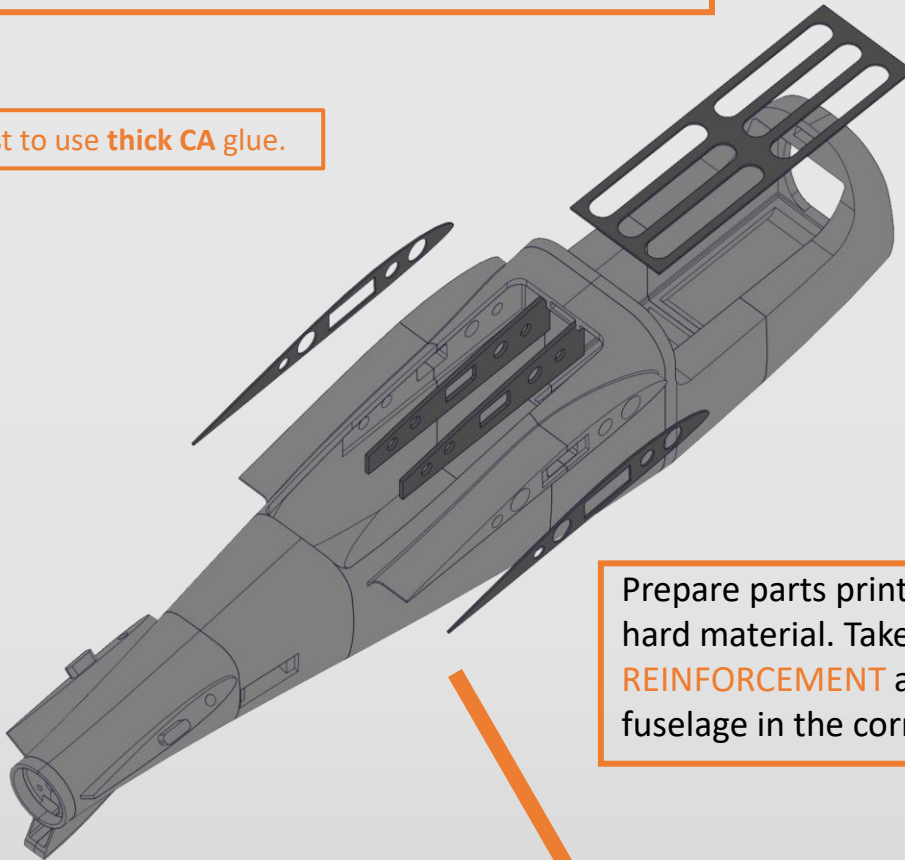

Prepare parts printed from PLA or other hard material. Take **FUS ROOT** and **INNER REINFORCEMENT** and glue with CA to the fuselage in the corresponding places.

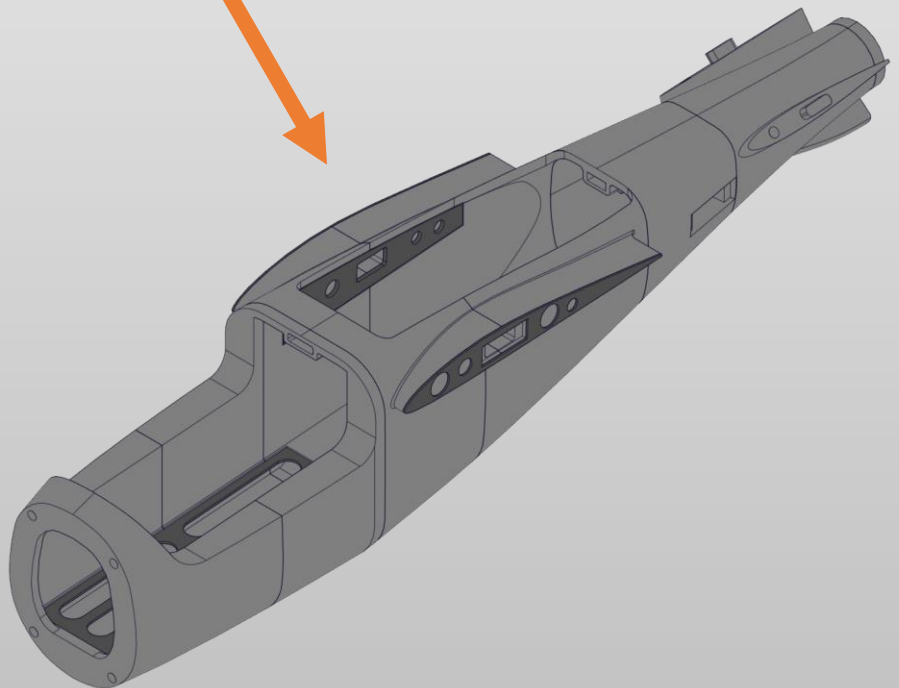

Fuselage assembly

Now take M3 threaded inserts with an outer diameter of 5mm. Glue them into the designated places in the front part of the fuselage. You can use a slightly heated soldering iron for this. Then glue **NOSE REINFORCEMENT** printed from PLA or other hard material. This noticeably increases the strength of the nose when it is frequently unscrewed and prevents the threaded inserts from being torn out.

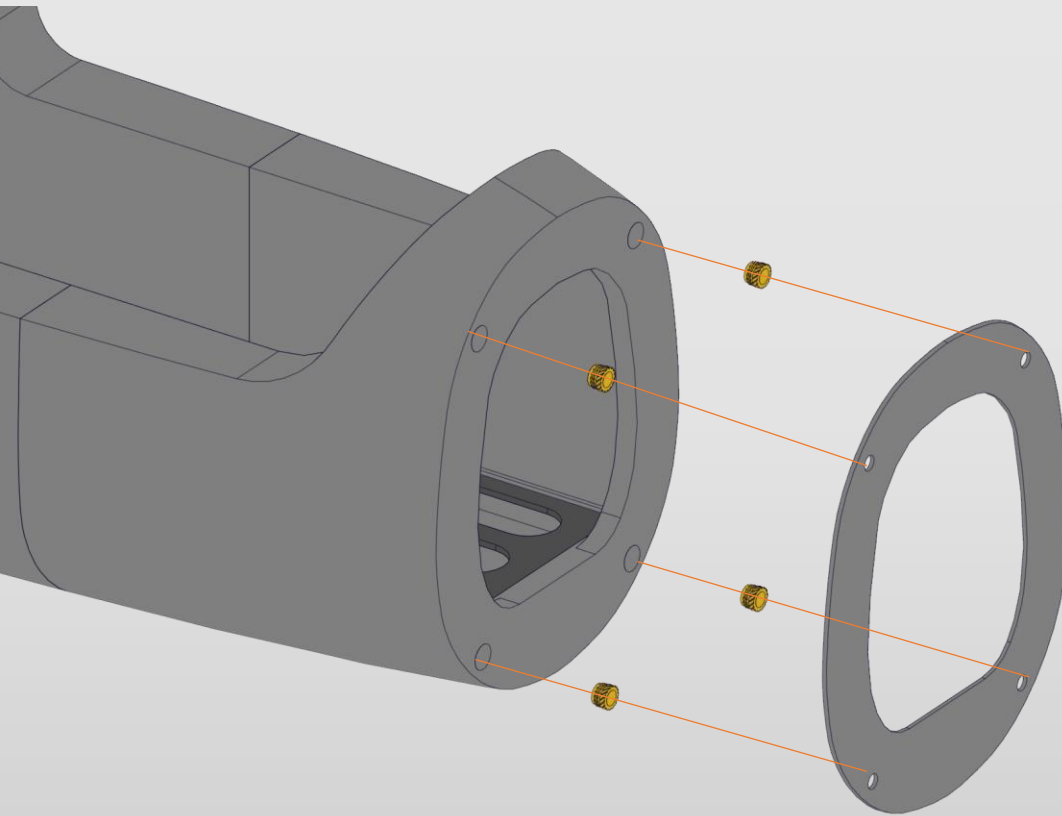

It's best to use **thick CA glue**.

Hatches

Prepare the front and center hatch. Both require **LOCK 1** and **LOCK 2**. Assemble the locks by adding a small spring and paste them into the designated places. Glue locks into the hatches using CA, but carefully so that the glue does not spill and block the lock.

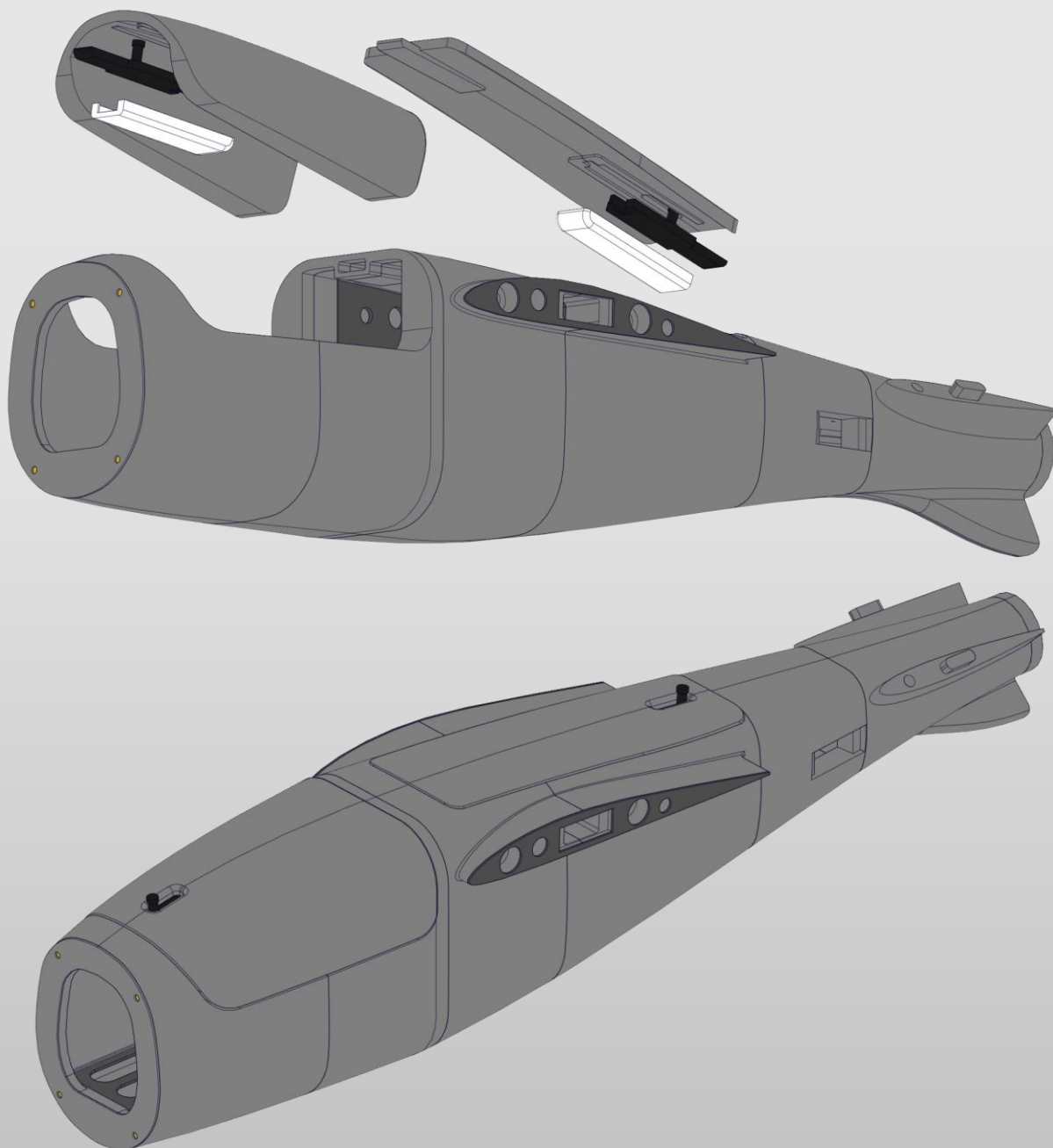

V-TAIL servos

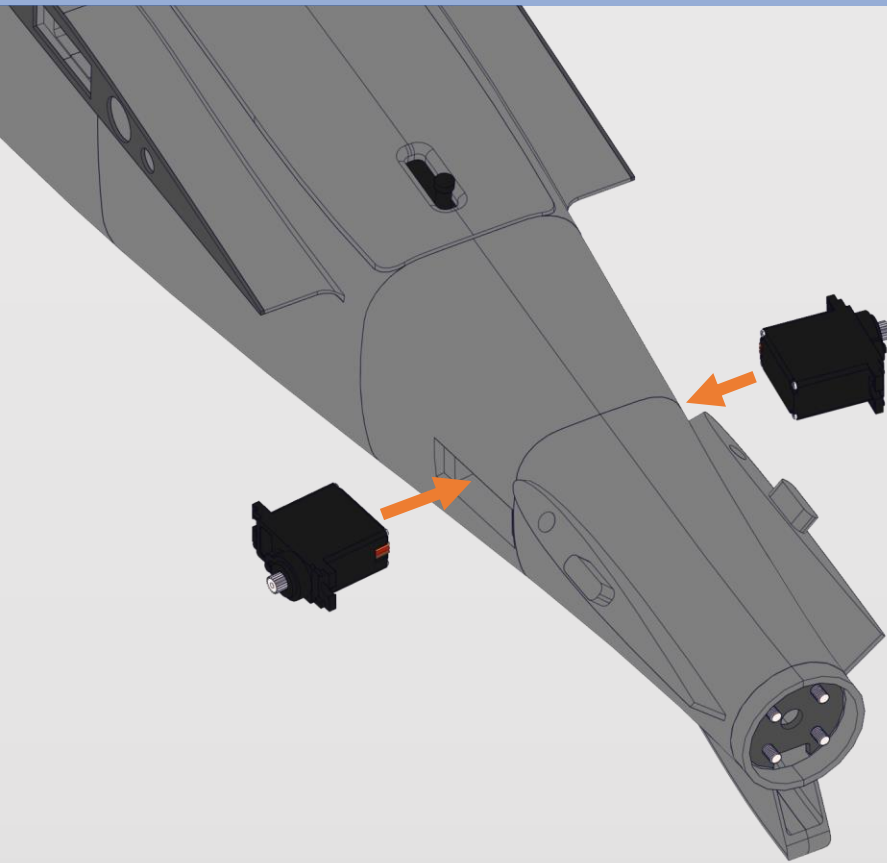

Now insert the V-tail servos into the designated places on the back of the fuselage. Micro servos of standard 9-12g weight will fit. Use a small amount of hot glue to secure them.

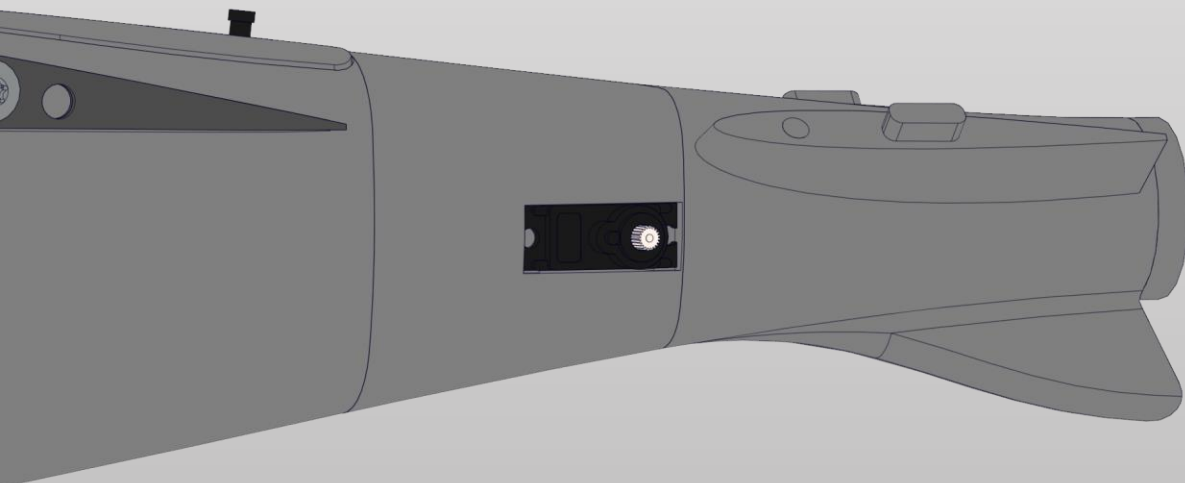

V-TAIL

Take V tail parts. Glue them together and use 4mm carbon tube cut to 130mm for reinforcement. Use 20x30mm polyester hinges to assemble the rudder by gluing them into the prepared places. You can also use thin hinges made of other thin materials

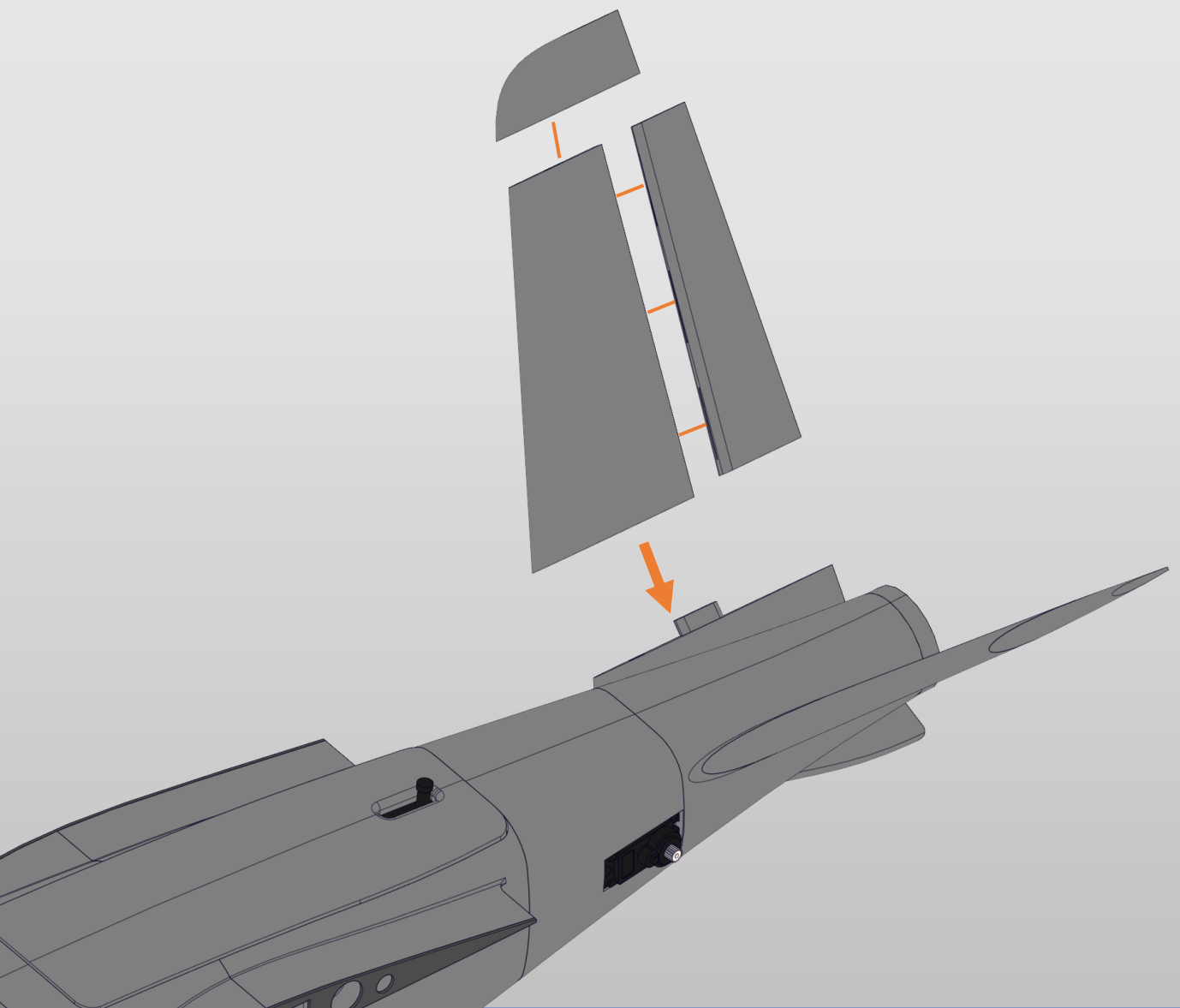

V-TAIL

Paste plastic control horns. A hole is prepared in the rudder. As you will notice, the hinge will prevent the horn from being inserted. Make a slight cut in the hinge and insert the horn. You can make the pushrod yourself from thin wire and bend it in Z, or use snaps.

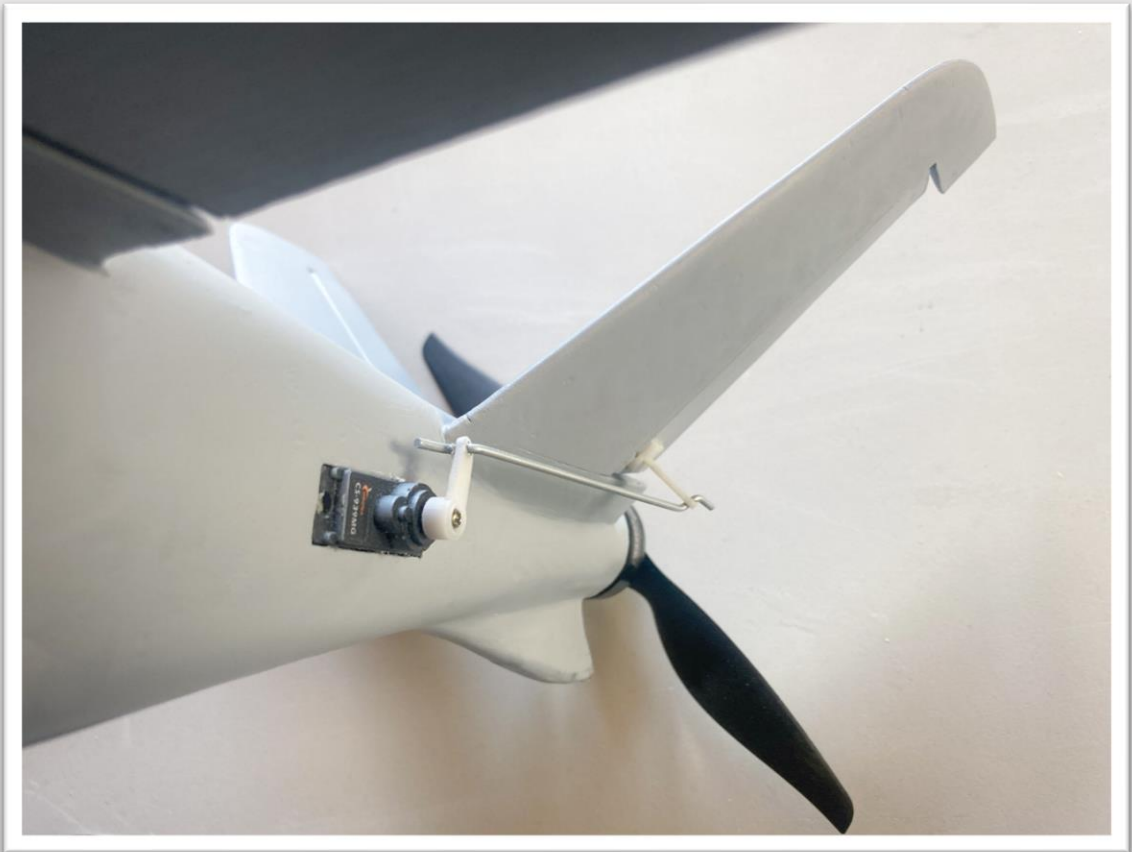

Motor mount

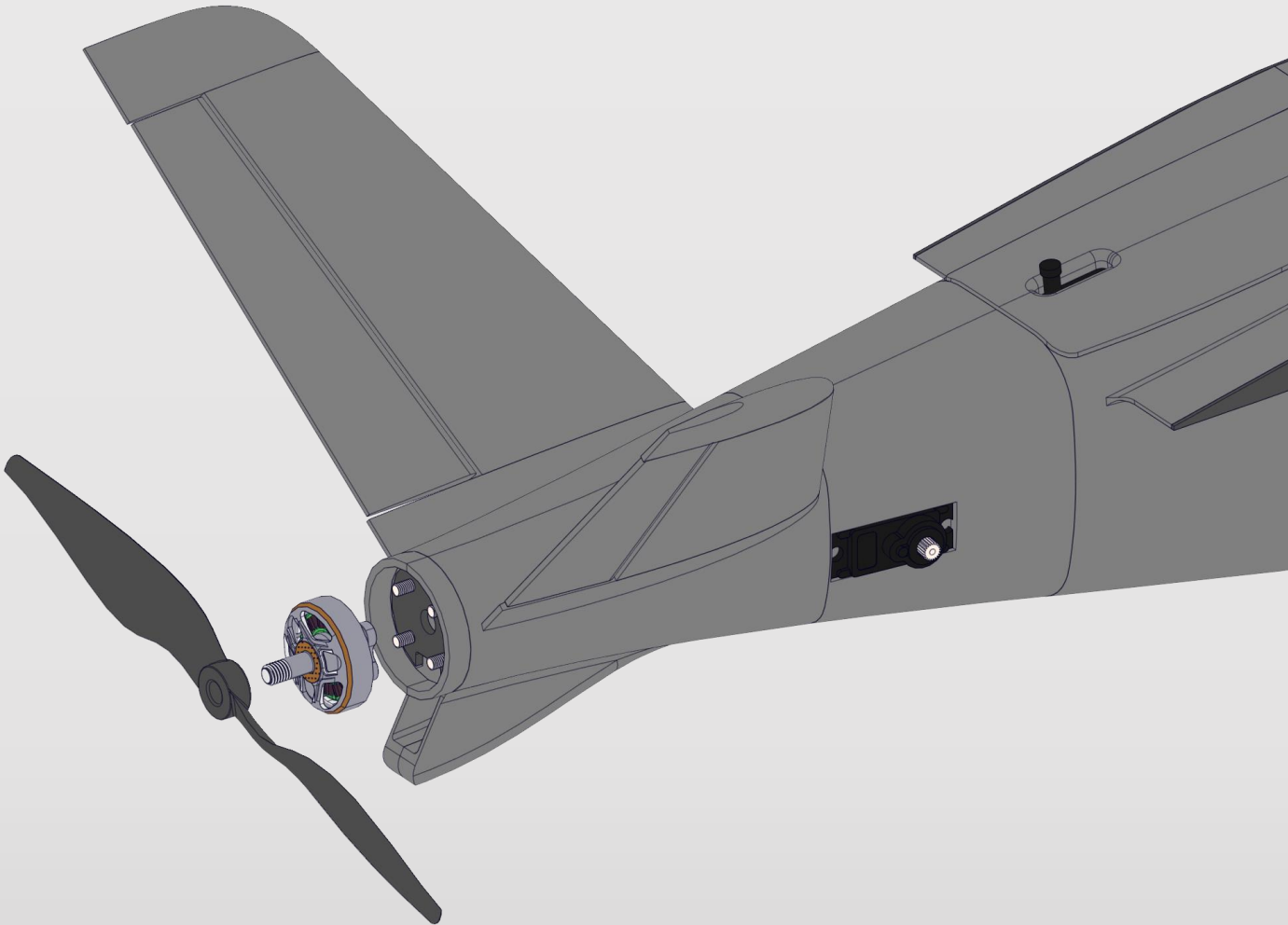

Now you can bolt the F90 motor from inside of the fuselage if you chose this solution. You can get there through the middle hatch. If you chose to mount the motor differently then you can bolt it on at any time.

Nose mount

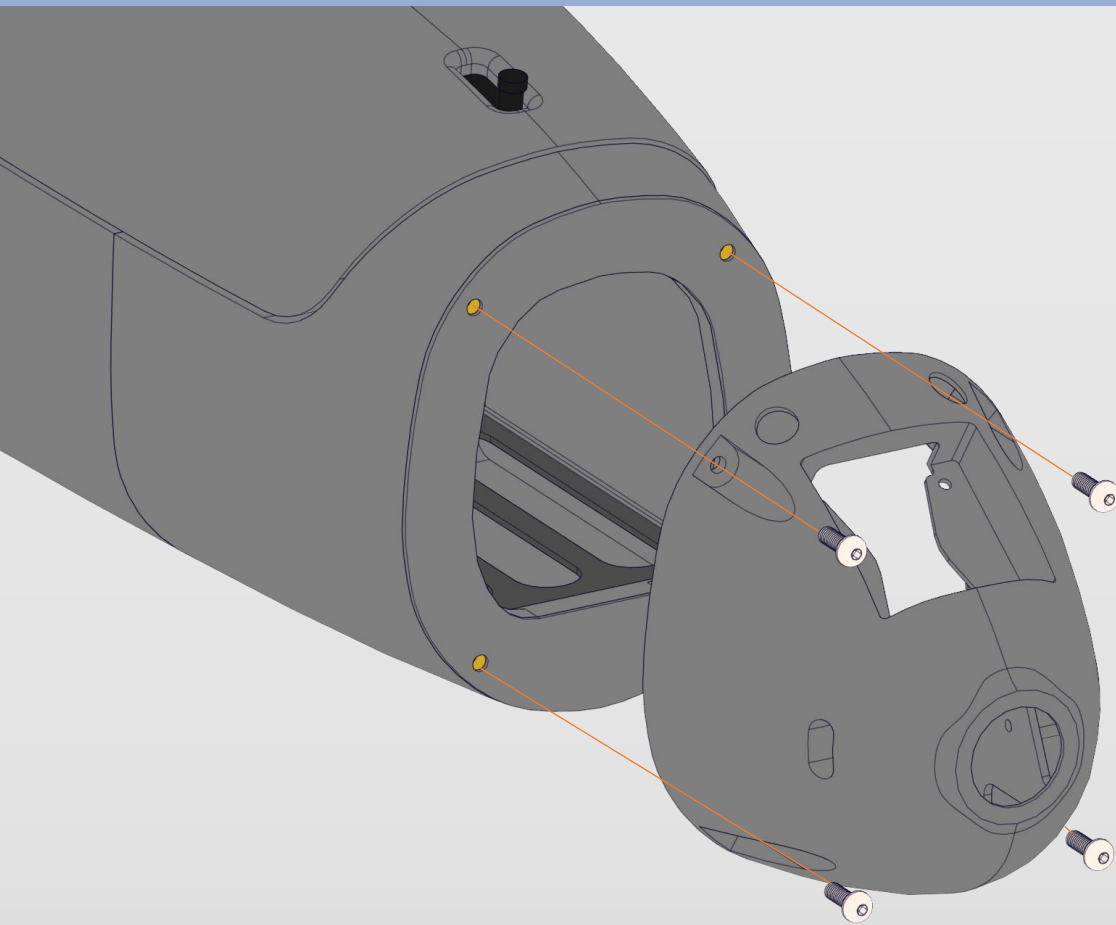

At this stage, you can pre-tighten the nose with short M3 screws and check that everything fits well.

Nose mount

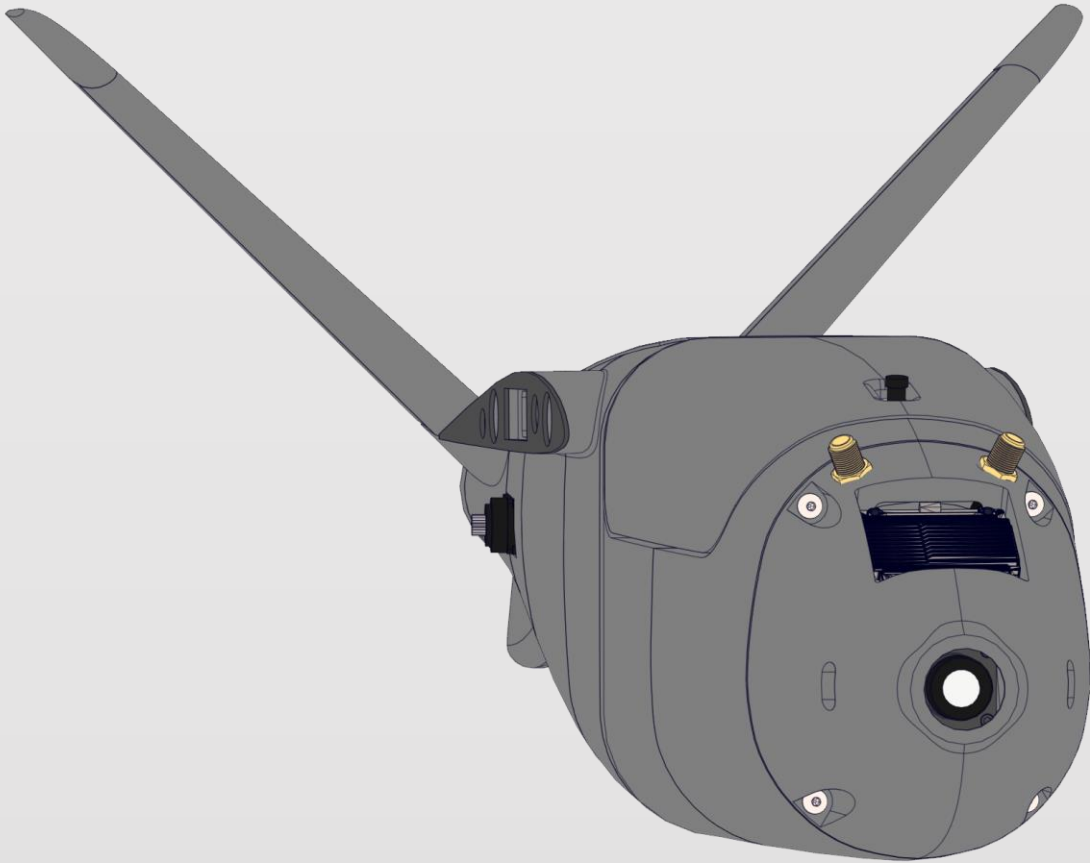

You can also prepare a nose printed from hard PLA. Version adapted for Walksnail is ready in the files. However, there is no problem to adapt it for another digital or analog system. ,Clean' nose version in STEP format is also available in the files. You can easily edit it for your needs.

If you are using Walksnail then I recommend using U.FL - SMA pigtail. This provides a solid mounting of the antennas directly next to the VTX.

Wings assembly

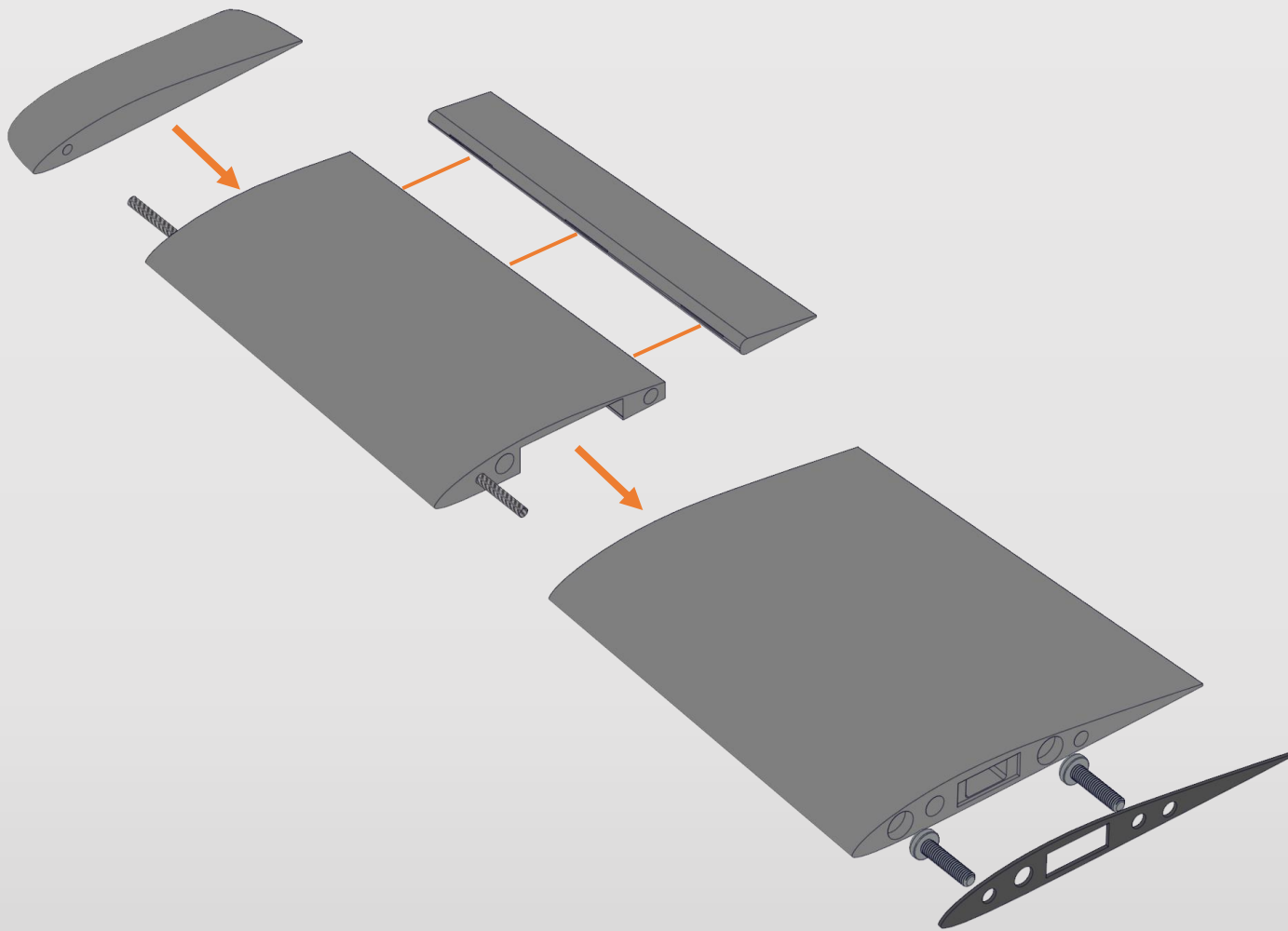

Take wing parts. Before gluing the segments together, insert a 4mm tube cut to 220mm into the designated place. The tube does not need to be glued. Fasten the aileron with thin 20x30mm polyester hinges similarly to the V-tail.

Wings assembly

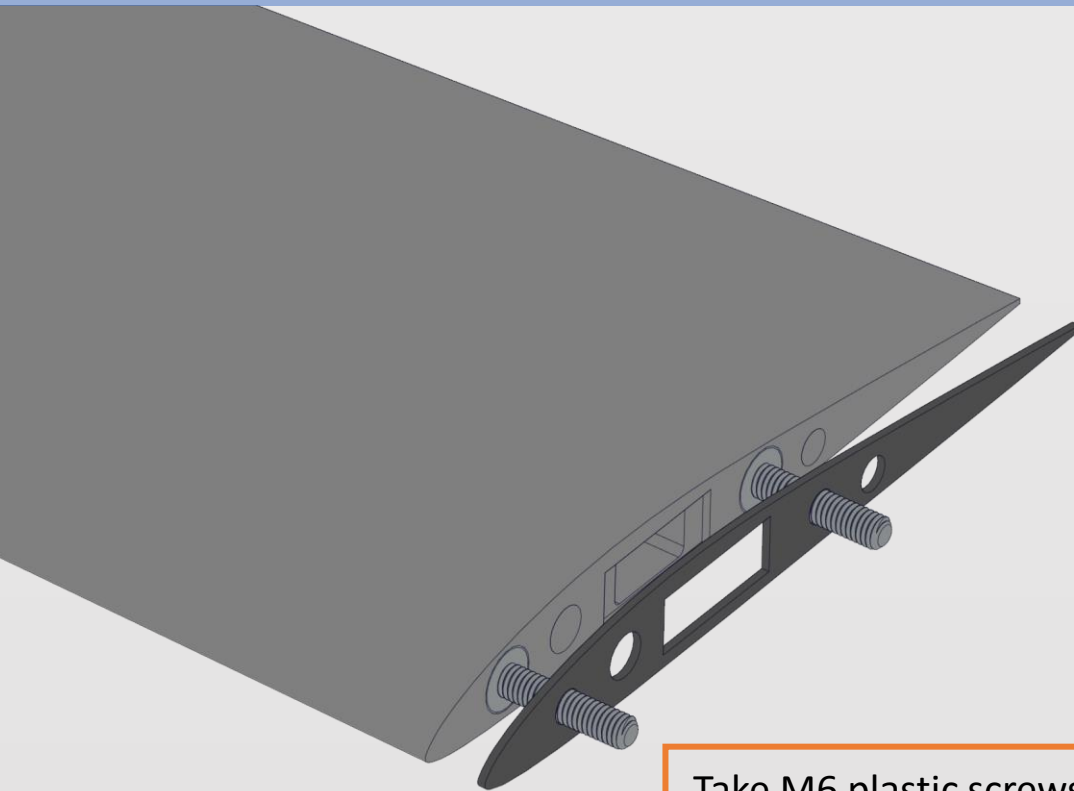

Take M6 plastic screws and paste them into the designated places. Then paste the **ROOT WING** as shown in the picture.

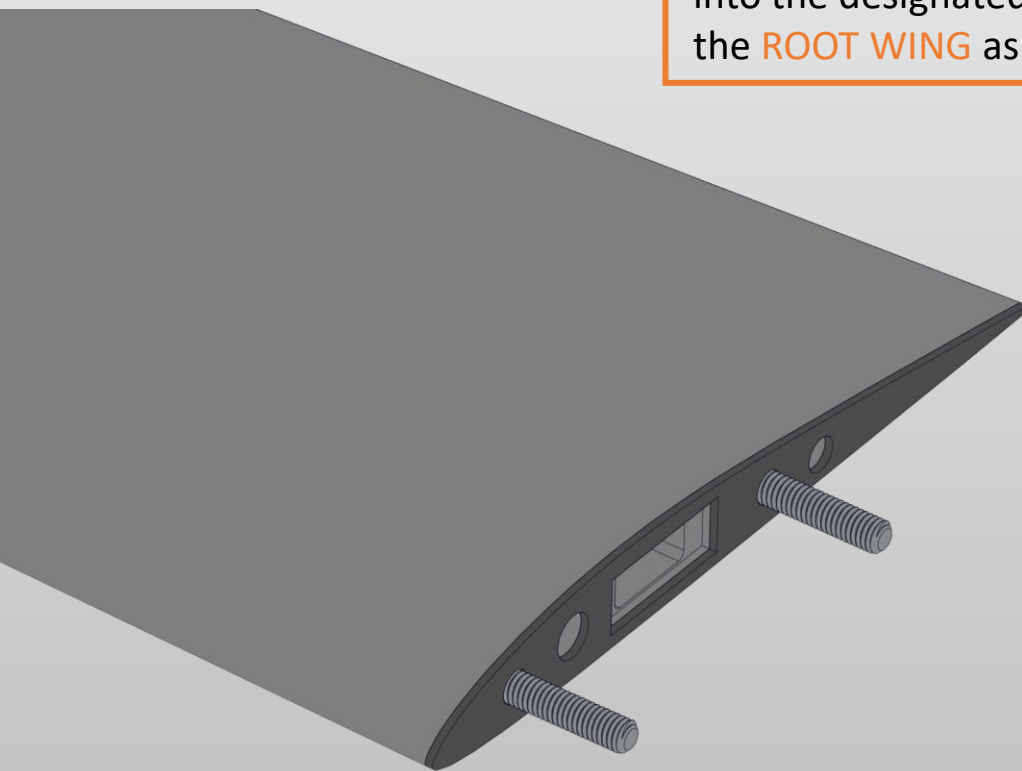

Wing assembly

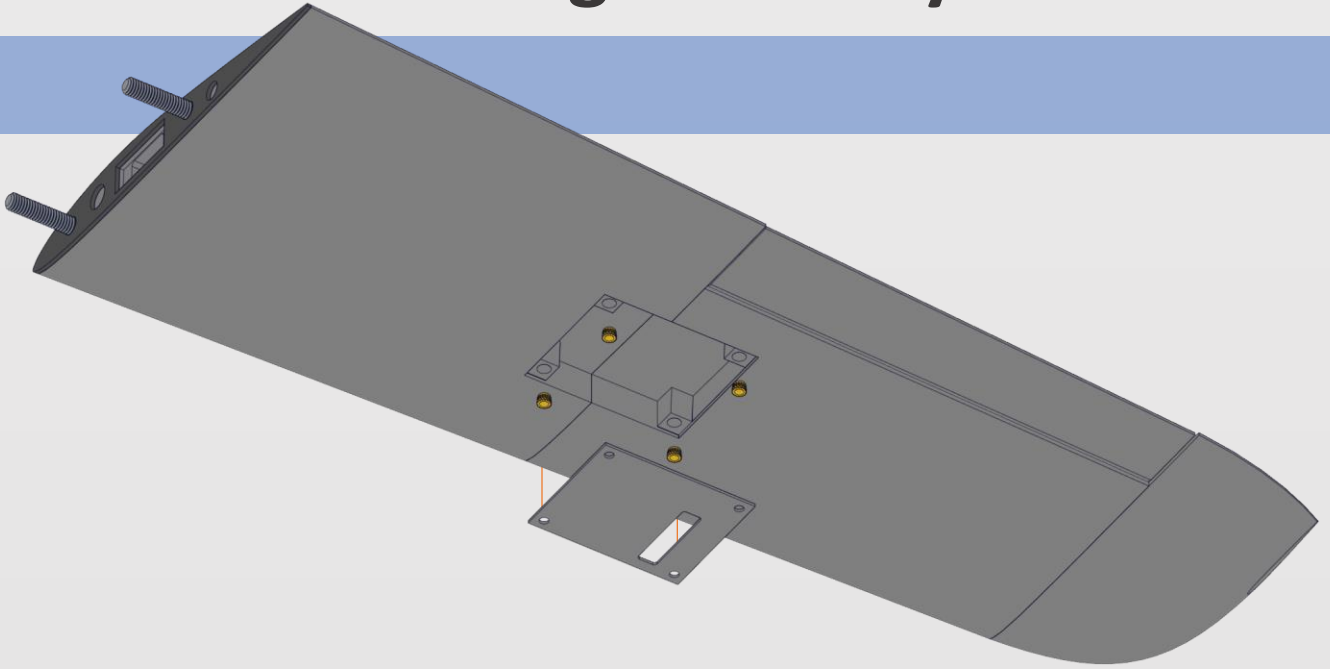

Now paste the M3 threaded inserts into the designated places on the wing. In the servo hole there is no prepared attachment for a specific servo model. You can use any servos that will fit. I recommend using thin wing servos such as CS239MG or others of similar size. You can also use standard micro servos, preferably they should not exceed 11mm thick. Paste the servo with hot glue and screw the servo cover with short M3 screws. Servo Cover is available in STEP format, if you want to make modifications here you can without any problem.

Paste plastic control horns. A hole is prepared in the aileron. As you will notice, the hinge will prevent the horn from being inserted. Make a slight cut in the hinge and insert the horn. You can make the pushrod yourself from thin wire and bend it in Z, or use snaps.

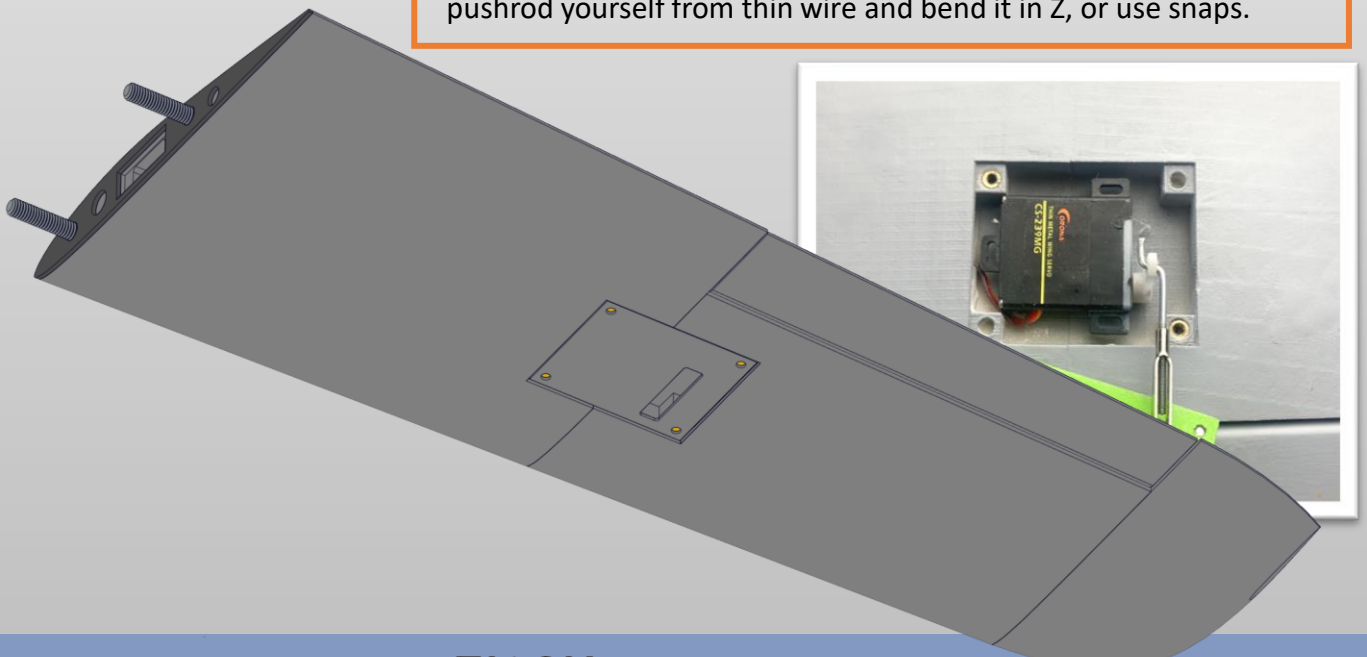

Wing mount

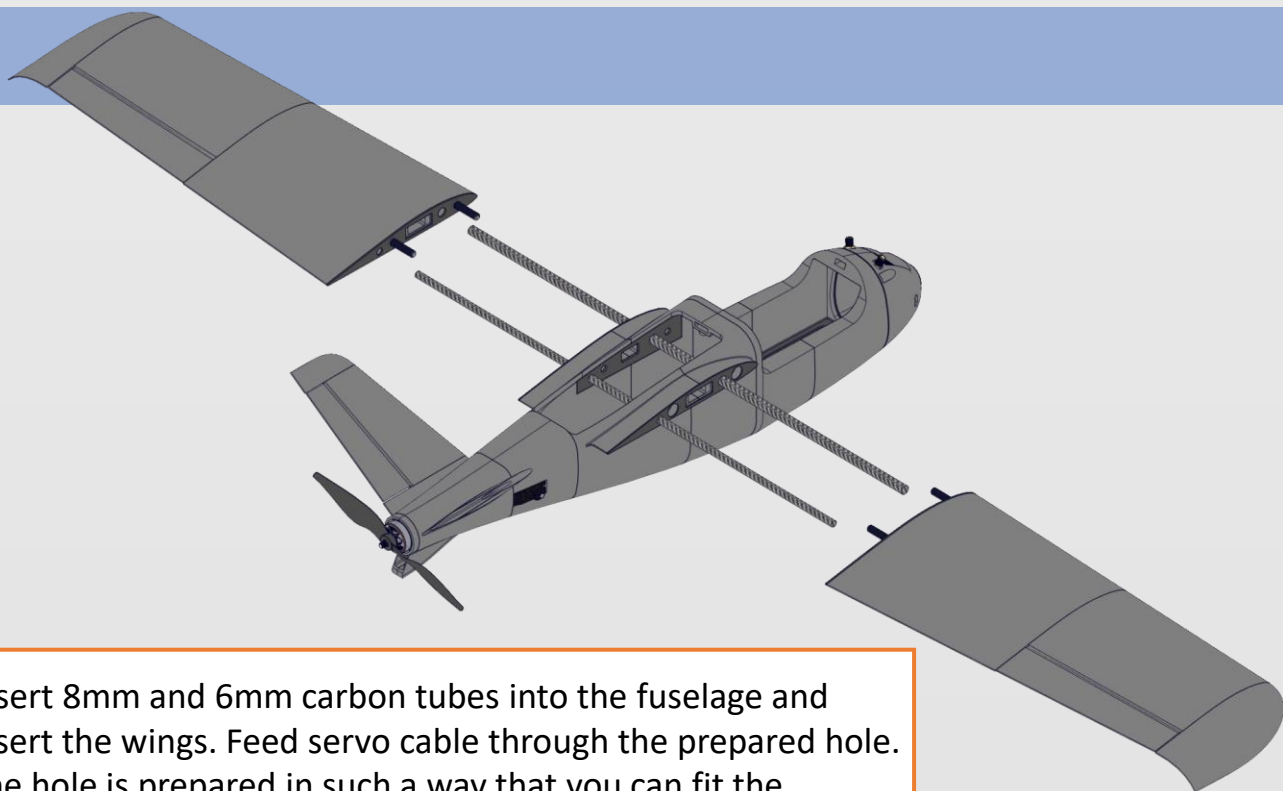

Insert 8mm and 6mm carbon tubes into the fuselage and insert the wings. Feed servo cable through the prepared hole. The hole is prepared in such a way that you can fit the housing for the MPX connector there. I personally do not use it here, but there is no problem to glue it there. Secure the wings by screwing them with M6 nuts from the inside of the fuselage. You can do it by hand without any problem.

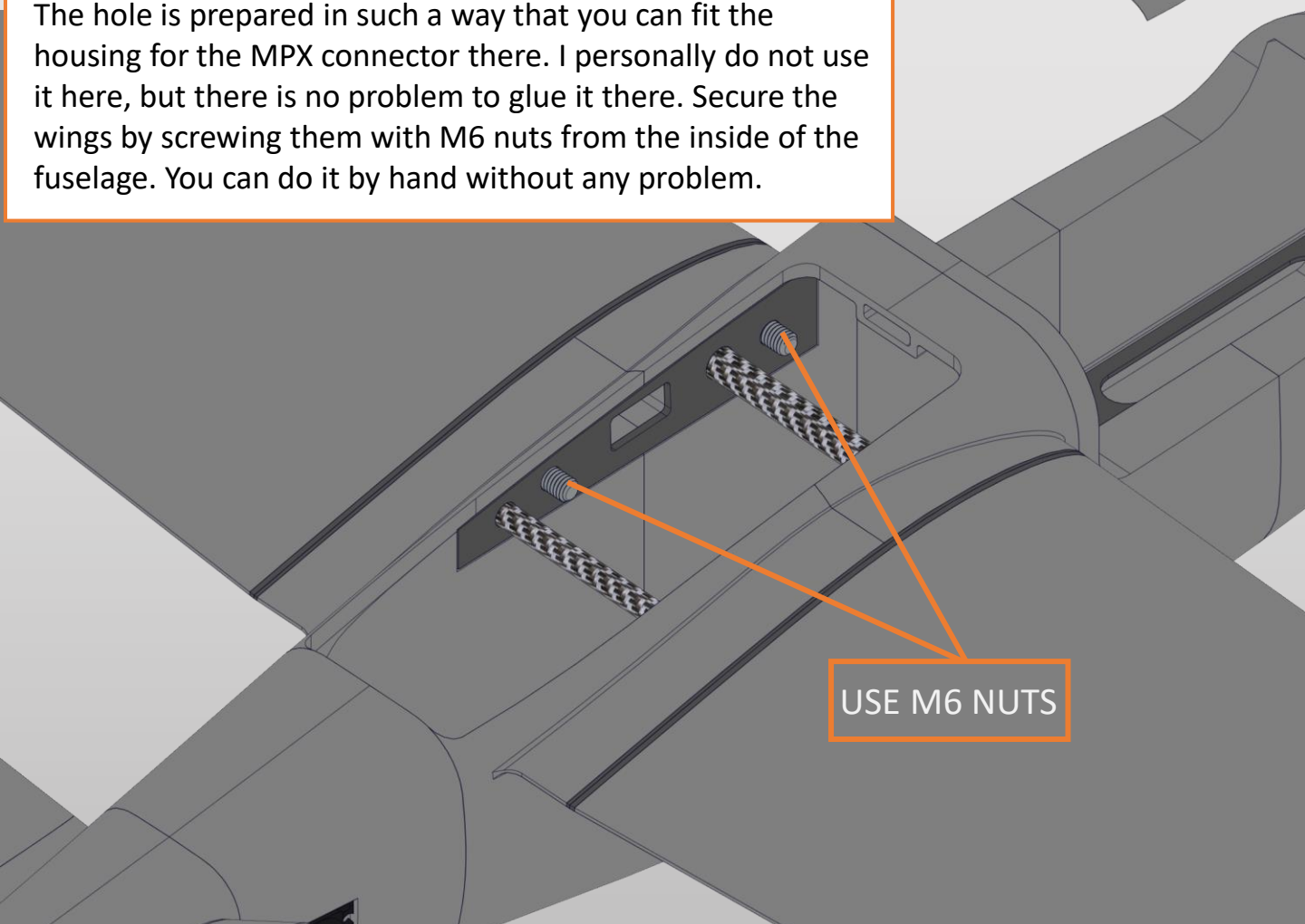

USE M6 NUTS

Equipment layout

Despite the aircraft's small size, the fuselage is spacious. A battery pad will fit a maximum of about 15cm long. Thus, a Lion 4S2P will fit in. Such a set will allow for about 2 hours flight. However I prefer a smaller load and recommend 4S1P or any other 4s pack weighing up to 300g. The space under the wings has a flat surface and is ideal for FC mounting. For example, you can mount it with self-adhesive Velcro. It will also fit the receiver there, and GPS a little behind.

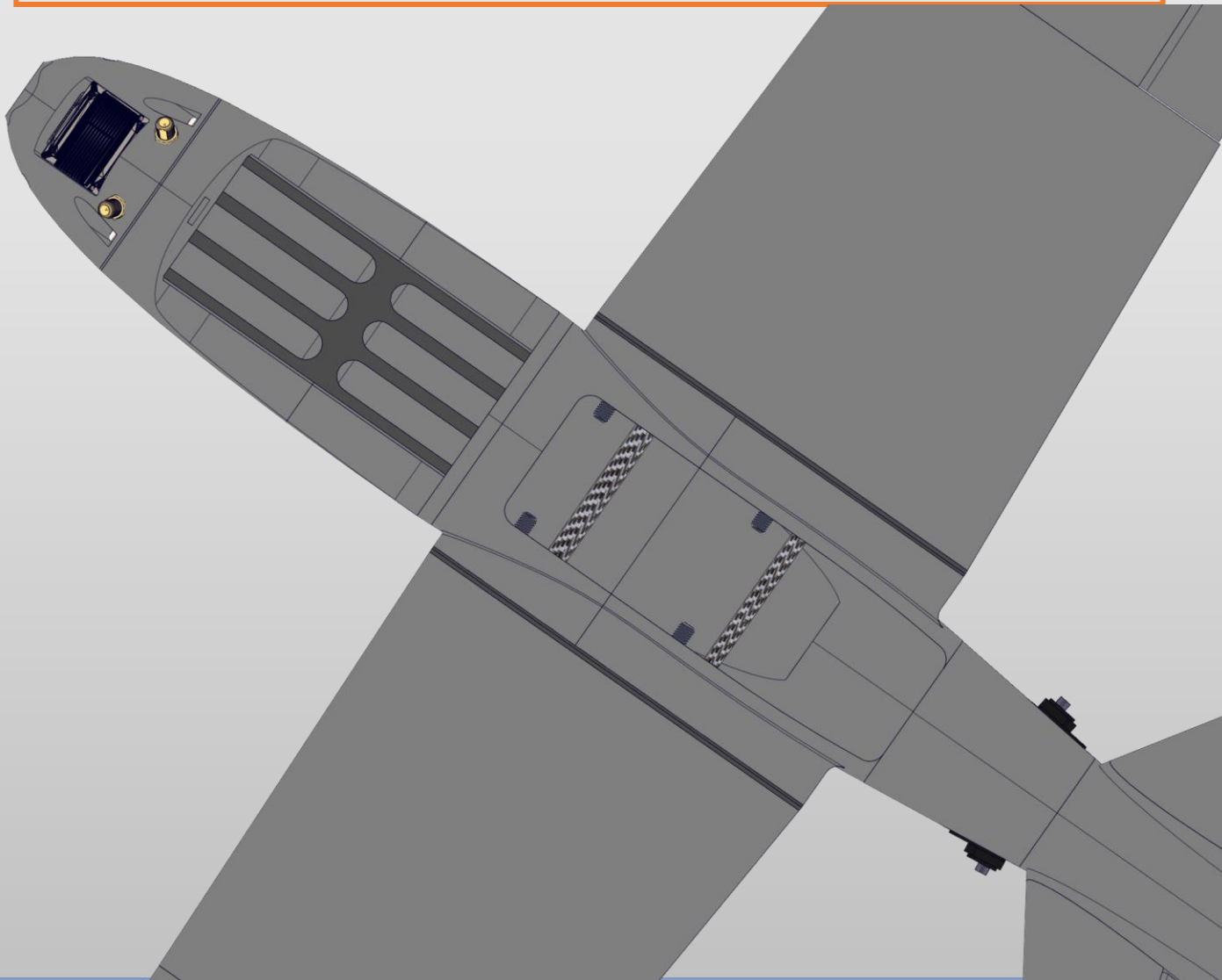

Finishing build

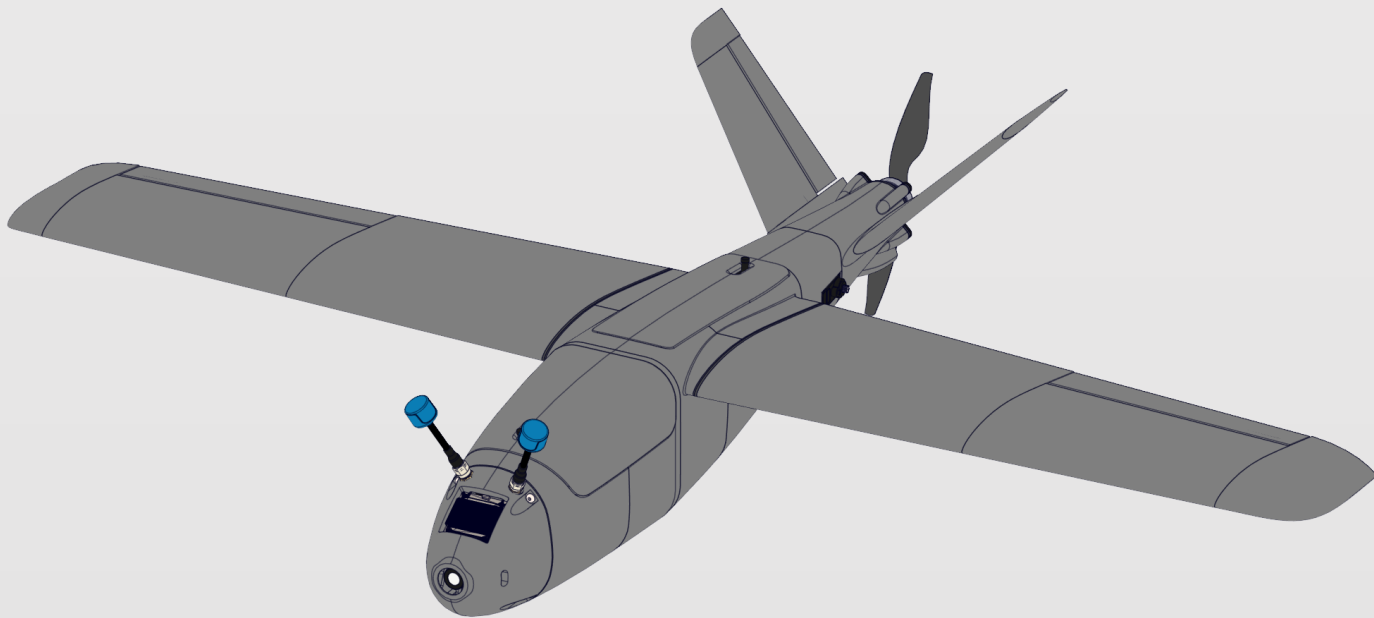

The model is practically ready. Before flying, make sure that the center of gravity is in the right place, 44 mm from the leading edge. Small tabs on the underside of the wings will help with balancing.

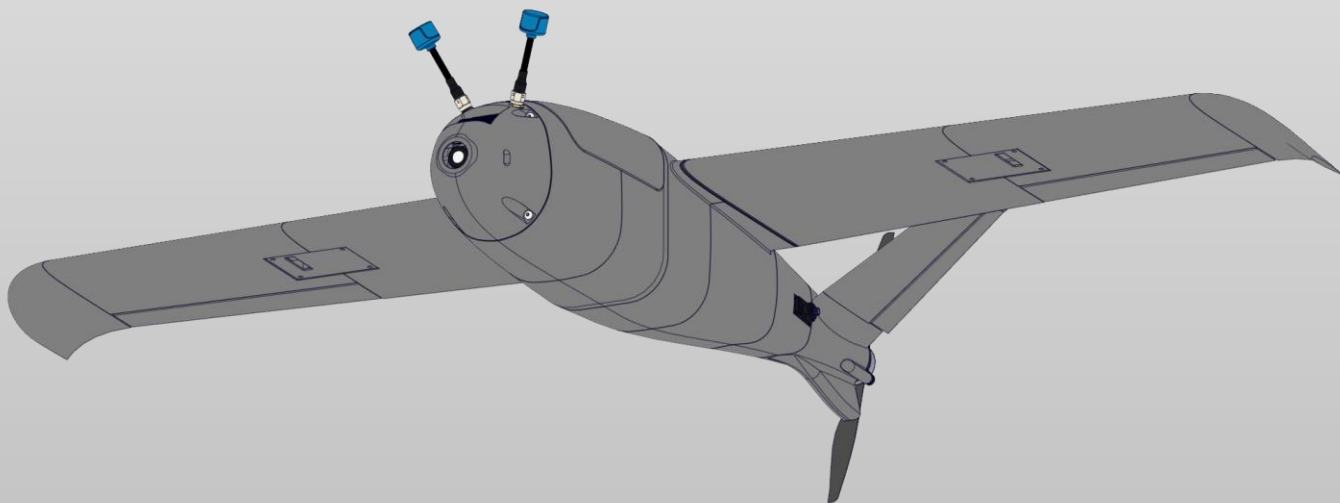

Ready to fly

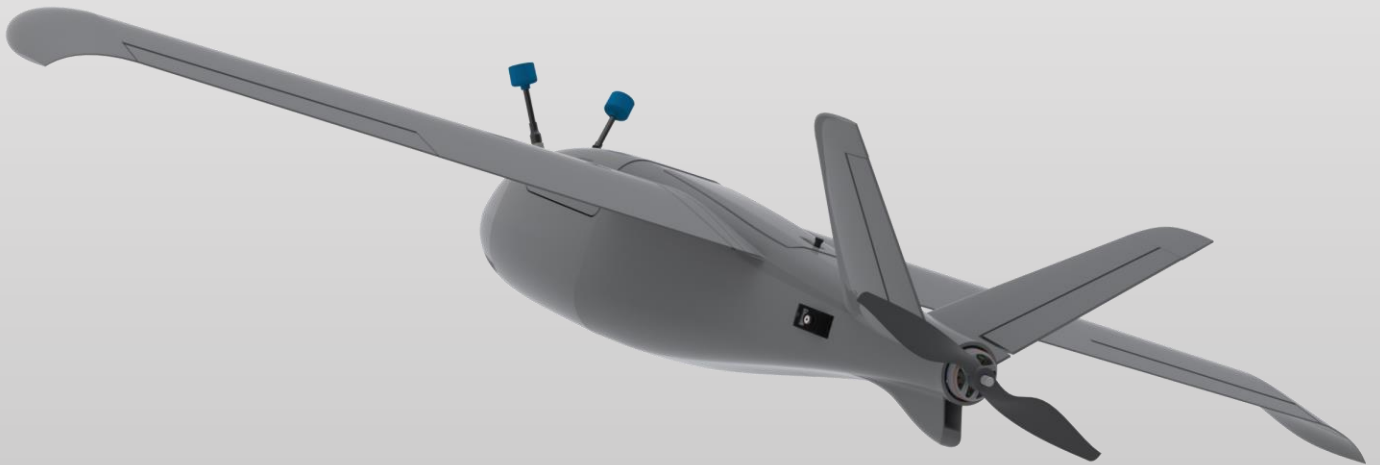
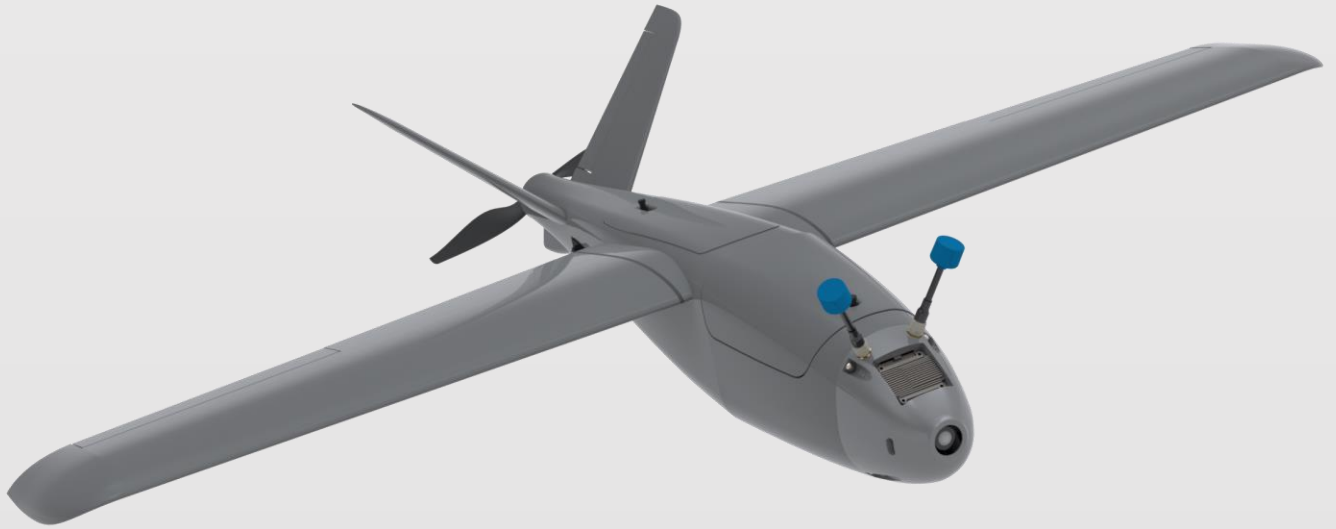

piCoTALON

