



# talon 1400



## USER MANUAL

V.1

© 2023 Flightory by Szymon Wójcik All rights reserved.

# Socials



Join Flightory Tech group on Facebook and create community with us. Share progress of your builds. Any suggestions or questions welcome.

[www.facebook.com/groups/flightory](http://www.facebook.com/groups/flightory)

Follow Instagram where I share more footage on a regular basis

[www.instagram.com/flightory/](http://www.instagram.com/flightory/)

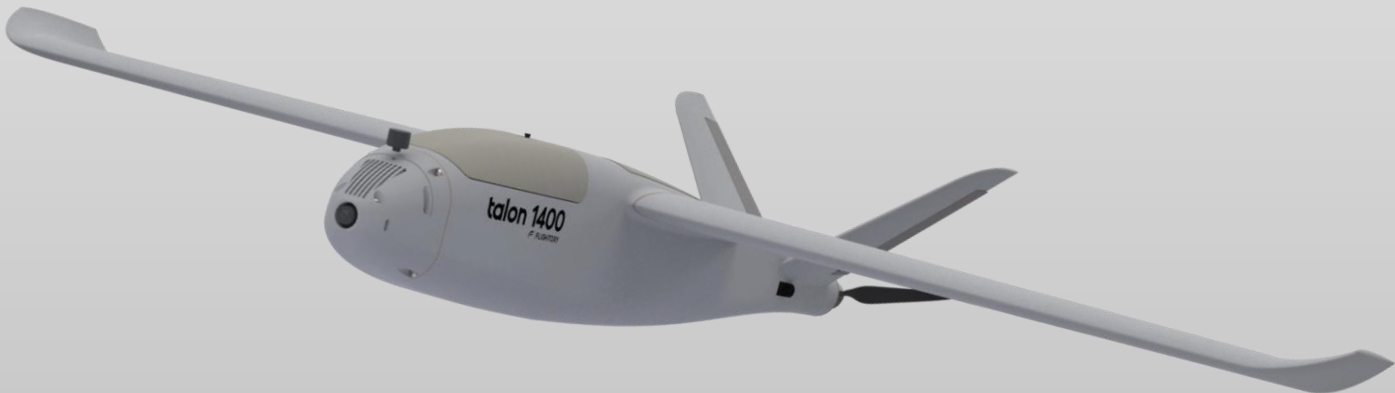

# General Aircraft Data

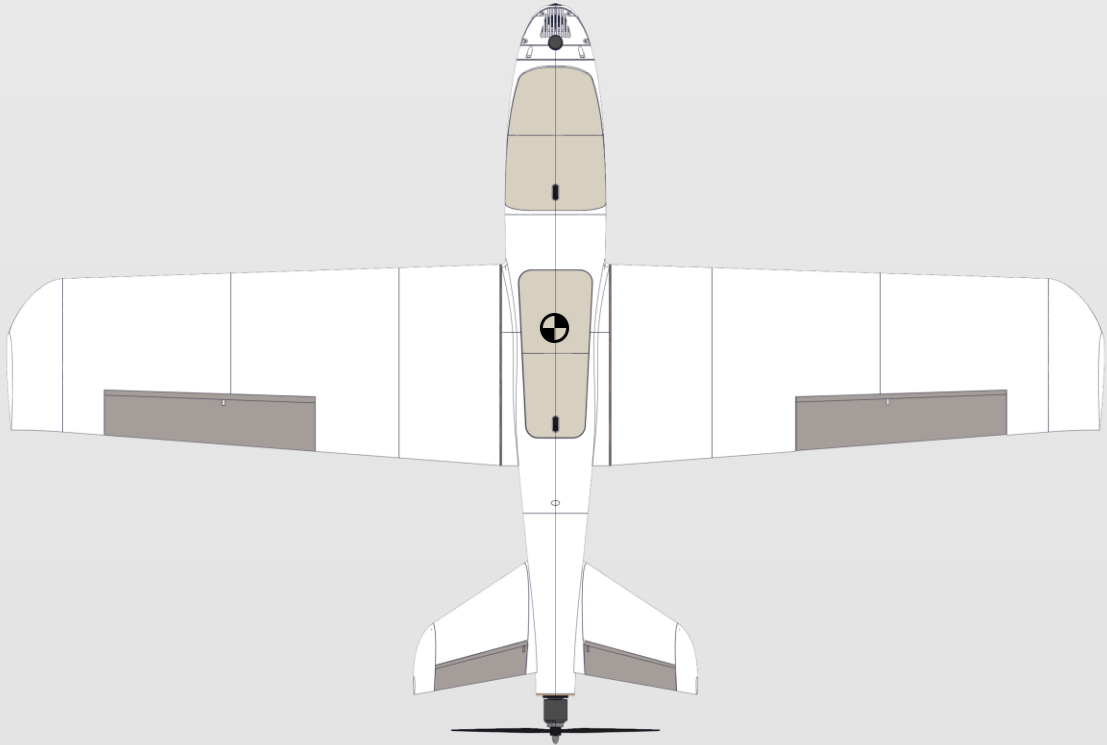

General data	
Wingspan	1305mm
Wing area	27.5 dm <sup>2</sup>
Length	830mm
Center of Gravity	65mm from leading edge
AUW	1500-3300g
Optimal Cruise Speed	55-65 km/h
Airfoil	Eppler E205
Root Chord	240mm
MAC	211mm
Aspect Ratio	6.3
Wing load	54 -120 g / dm <sup>2</sup>

# General Aircraft Data

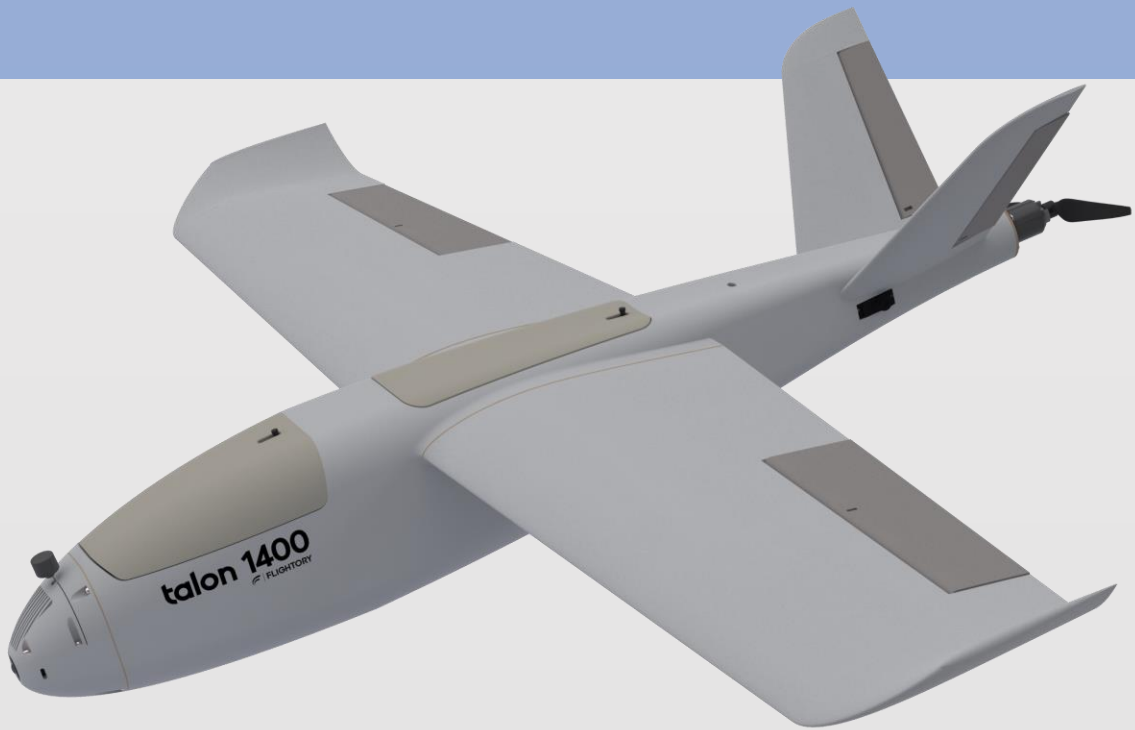

The aircraft is a 3D printed UAV platform in a size that combines compactness and high flight performance. Talon 1400 is in the popular layout with single push propeller. The design focuses on optimizing flight performance as possible, accommodating large battery pack and additional equipment, and modularity. The geometry was carefully refined and studied using CFD and real-world flight tests. Using optimal equipment and a large 4S6P battery, you can achieve a flight time of about 4 hours. Easy accessibility for everyone and the possibility of using different types of equipment is also an important aspect. The aircraft has two tail variants to fit popular motor sizes. You can decide which motor you will use. In addition, the nose is also available in two versions and is fully detachable. You can choose a version with a VTX placed on the nose along with a 19x19mm FPV camera or a clean option, with the FPV camera alone. In addition, the nose as well as several other important parts are available in STEP format, which allows easy editing and customization for more individual needs. If you need to customize the nose to mount another payload then you can easily do so. You can have several versions of the nose and change them during the life of the model depending on the needs of the flight.

# CFD Analysis

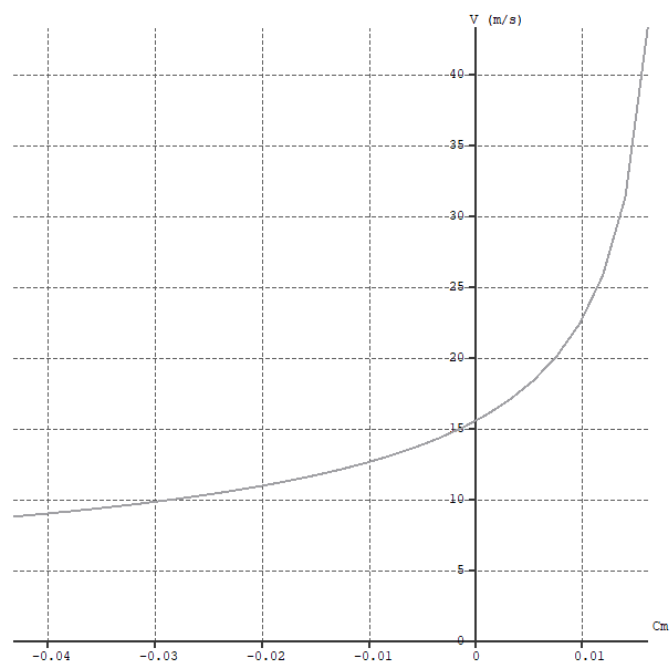
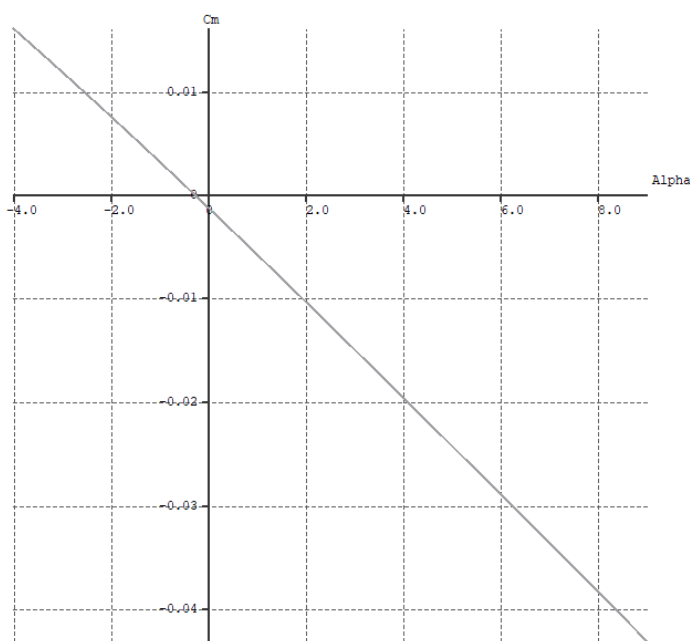
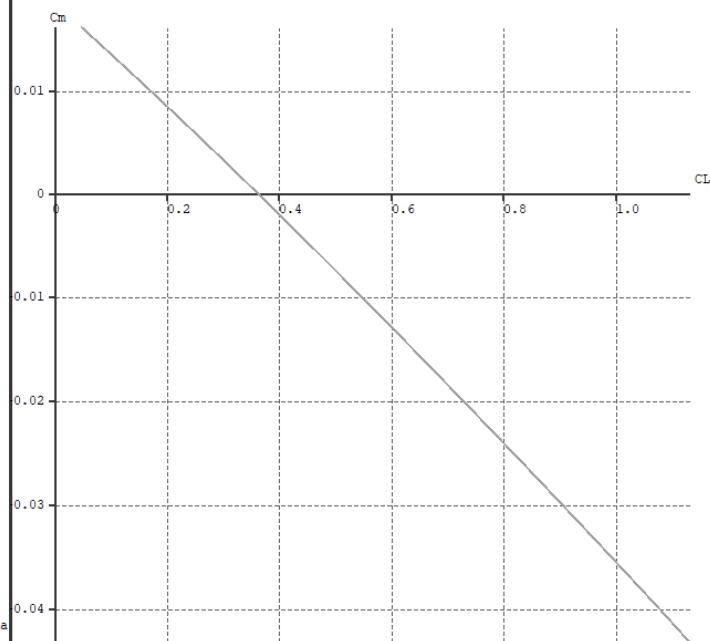
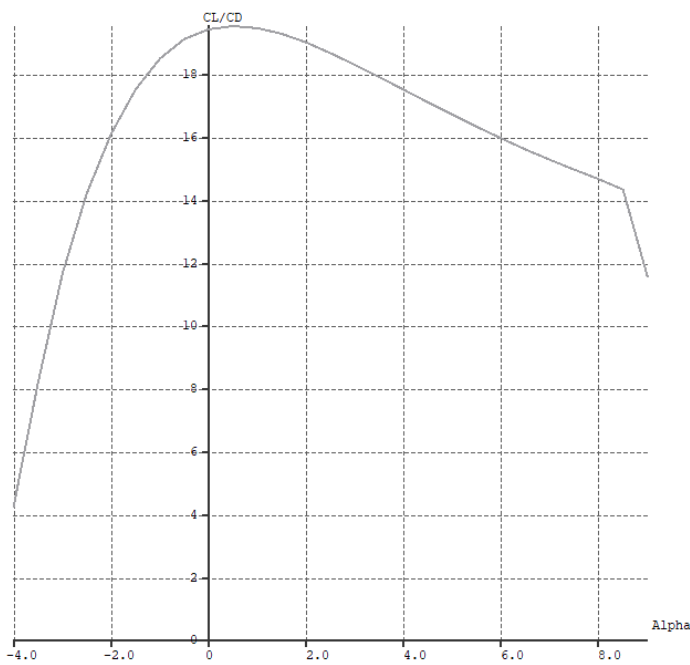

The geometry is designed to provide the best possible characteristics. Eppler E205 airfoil was selected. The shape of the wing and the V-tail stabilizers, as well as their mutual position and incline angles, were optimized to ensure high performance as well as longitudinal stability. At around zero AOA, the aircraft shows no pitching moment. Optimal aerodynamic performance is in the limit from 0 to 2 degrees of AOA and at speeds from 55 to 65 km/h. With a proper center of gravity position of 65mm from the leading edge, the aircraft does not require any trim, and its natural stability allows it to fly in manual mode as well, or without a flight controller.

# Exploded view

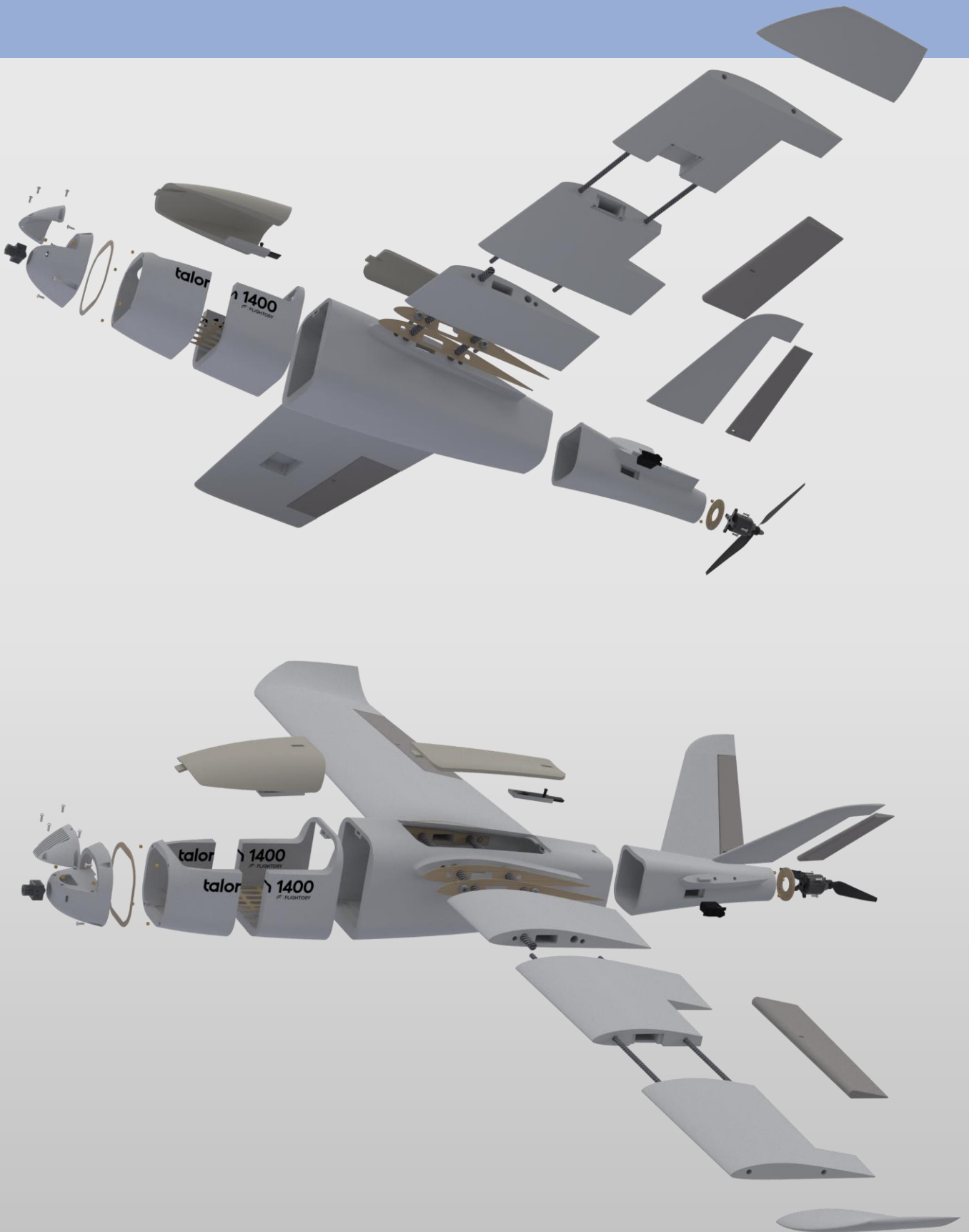

# Reccomended RC Equipment

Reccomended electronics	
Motor	2830 1200KV Prop Drive / 4108 620KV
Propeller	10x5 (2830 Motor) / 12x10 or 13x8 (4108 Motor)
Flight Controller	Speedybee F405 Wing or any other Mavlink FC
GPS	Matek M10Q or similar GPS with compass
Servos	4x Corona 929MG Metal Gear or similar
ESC	BIHeliS 40A
Battery	4S (max 4S6P 21Ah Li-Ion) or smaller pack / similar LiPo
Receiver	Matek R24-D ELRS or similar
VTX	Digital or analog VTX

# Required accessories

ITEM	QUANTITY
10x530mm Carbon Tube (MAIN SPAR)	2
6x435mm Carbon Tube (SECOND SPAR)	4
4x190mm Carbon Tube (VTAIL SPAR)	4
Thin CA Glue	20g tube
CA Activator	1 (optional but useful)
M3 Threaded Insert (Outer Ø5mm, height 5mm)	20
M3 screw	20
Plastic M6x45mm screw	4
M6 nut	4
LW-PLA	1 roll
PLA	Small amount
Polyester hinge 20x25mm	12
Pen spring	2
Velcro strap	2
Servo extension cable	2 (optional)



# PARTS LIST - FUSELAGE

PART	MATERIAL
FUS 1	LW-PLA
FUS 2	LW-PLA
FUS 3	LW-PLA
FUS 4	LW-PLA
FUS 5 (2830 motor)	LW-PLA
FUS 5 (4108 motor)	LW-PLA
HATCH MIDDLE 1	LW-PLA
HATCH MIDDLE 2	LW-PLA
HATCH FRONT 1	LW-PLA
HATCH FRONT 2	LW-PLA
NOSE	LW-PLA
NOSE VTX COVER	LW-PLA
NOSE CLEAN	LW-PLA
INNER REINFORCEMENT (print 2)	PLA
NOSE REINFORCEMENT	PLA
BATTERY PAD	PLA
FUS ROOT L / R	PLA
FIREWALL 2830 MOTOR	PLA
FIREWALL 4108 MOTOR	PLA
4108 MOTOR MOUNT	PLA
LOCK 1 (print 2)	PLA
LOCK 2 (print 2)	PLA

# PARTS LIST - WINGS

PART	MATERIAL
WING 1 L /R	LW-PLA
WING 2 L /R	LW-PLA
WING 3 L /R	LW-PLA
WINGLET L /R	LW-PLA
AIL L / R	LW-PLA
SERVO COVER (print 2)	PLA
WING ROOT L /R	PLA

# PARTS LIST - VTAIL

PART	MATERIAL
V TAIL 1 L /R	LW-PLA
V TAIL 2 L /R	LW-PLA
V TAIL RUDDER L / R	LW-PLA

# Print Settings

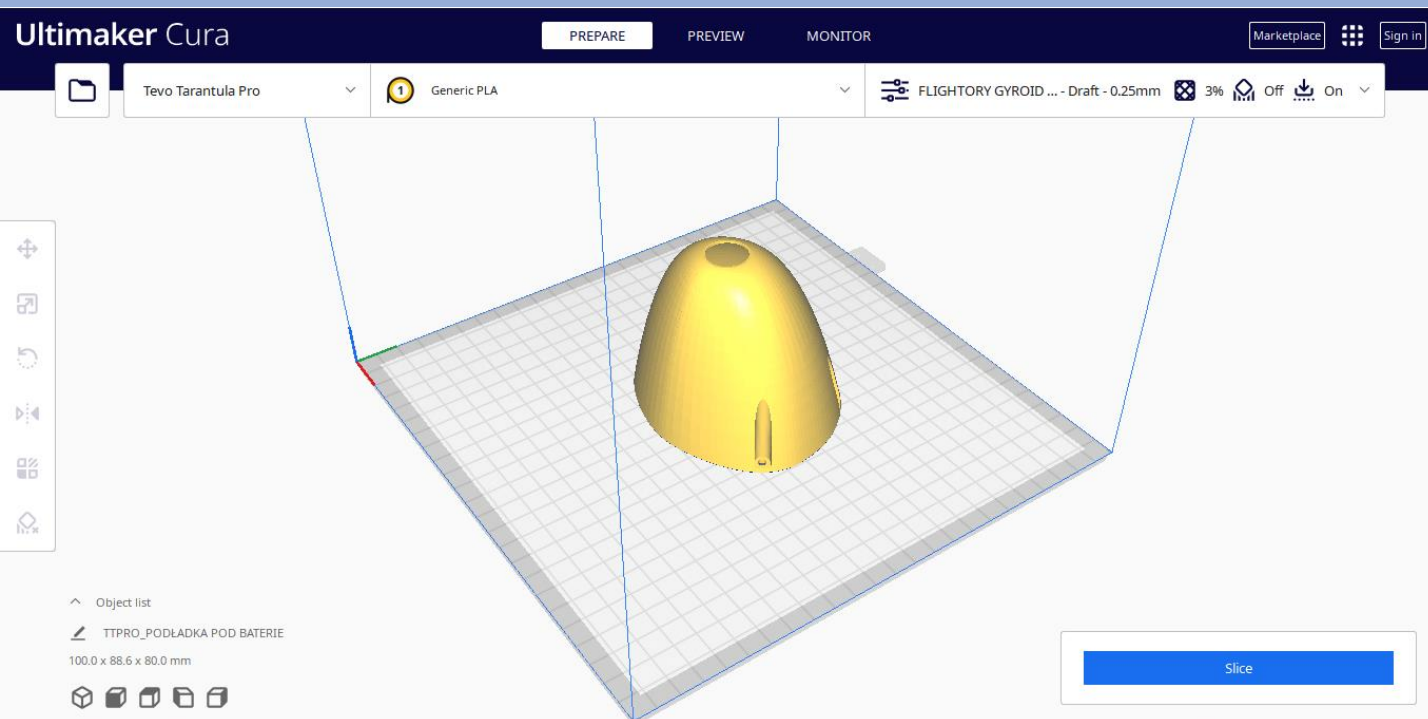

Slicer software you need to use is Ultimater Cura. All elements from **LW-PLA** are best printed with ready-made settings prepared in a profile that you can download. Settings are prepared a standard 0.4mm nozzle. Download link is available on Flightory Blog. **Infill in this profile is set to 6%. For this project I recommend changing it to 3% for most parts. This is sufficient infill**

Main features of slicer LW-PLA profile

- layer height: 0,25 mm
- single wall 0,4mm thickness
- 3% Gyroid infill.
- Temperature: 235 degrees,
- flow 60%
- fan speed: 0%

The rest of the detailed settings are saved in the profile.

To print hard **PLA** or **PET-G** parts, use a default profile in CURA called **Draft**. **Layer height is 0.2 mm, infill is 20% Grid pattern**. Set the temperature around **220 degrees**. You can fine-tune these parameters to suit your needs and your printer.

# Print Settings

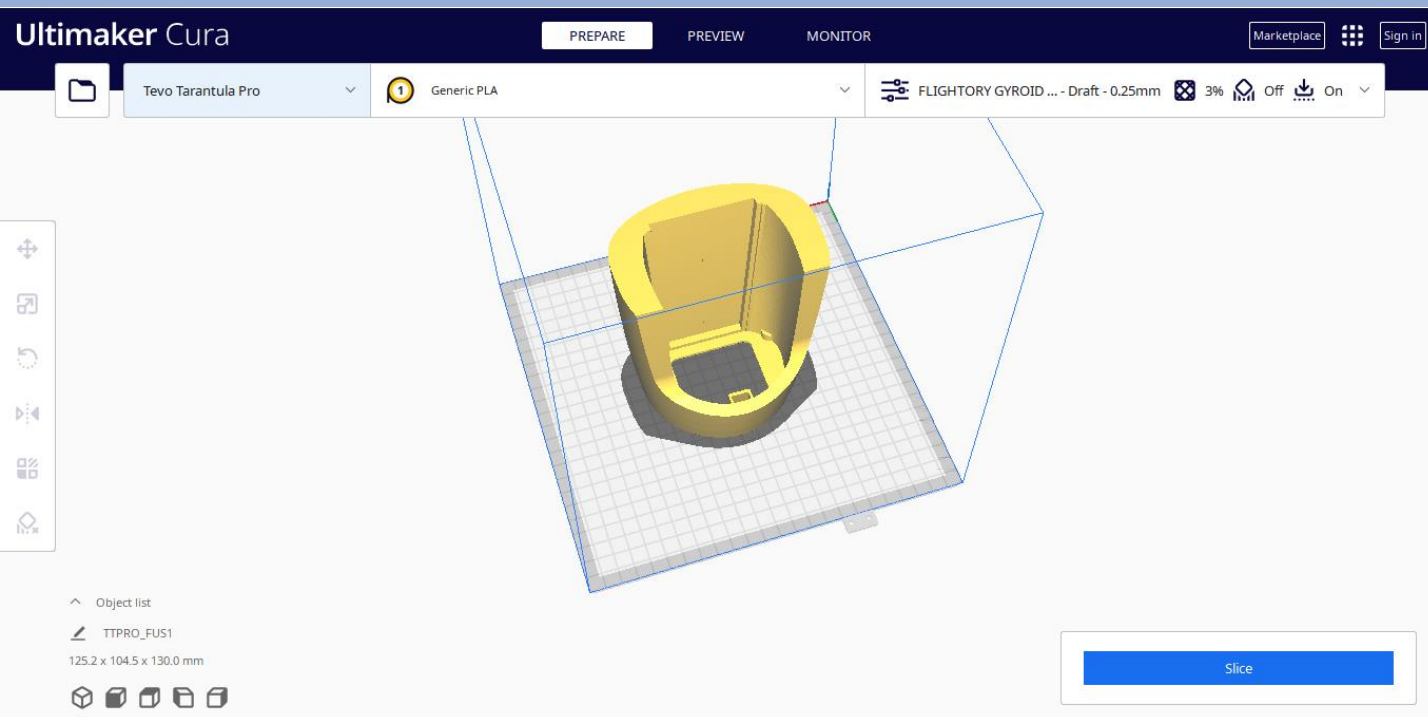

All parts are suitable for printing on any standard printer with a small working area. I printed all parts on a 200 x 200mm area. The settings are just a base that you can change and adjust as needed. The following pages will list my recommended infill settings for each part.

All elements can be printed without supports, but your printer may have a problem with some horizontal surfaces in some places. Depending on the effects, you may then consider turning on supports for these elements and cleaning the printed elements afterwards.

# Parts Orientation

Important thing is the correct orientation of the printed parts to avoid overhangs, and not have to use supports.  
Below is the recommended orientation of parts and infill settings.

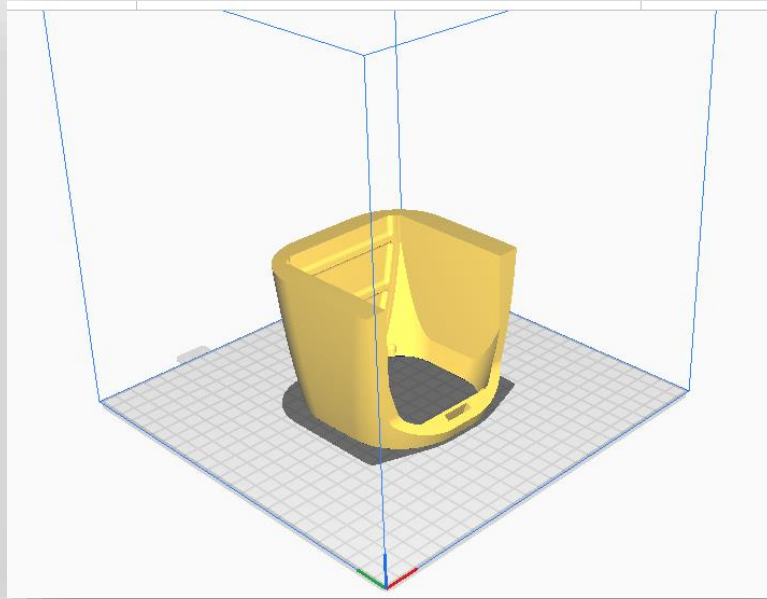

FUS 1 - 3% gyroid infill

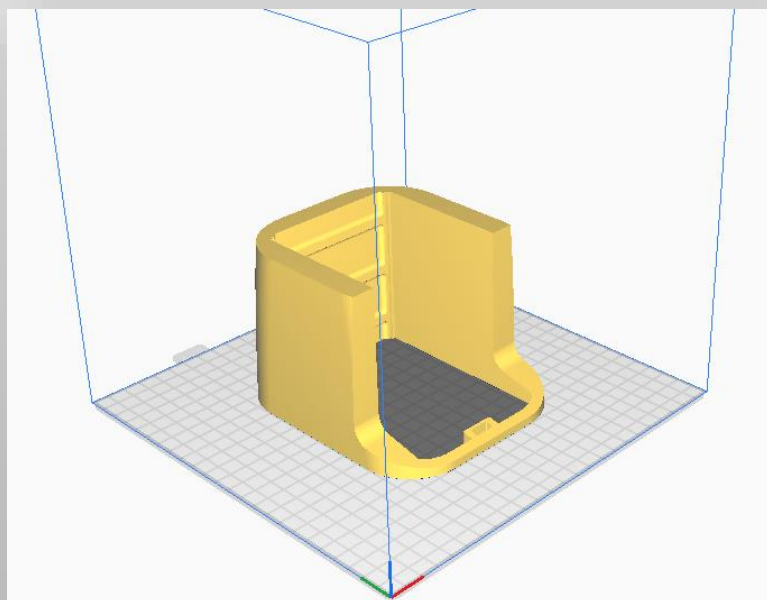

FUS 2 - 3% gyroid infill

# Parts Orientation

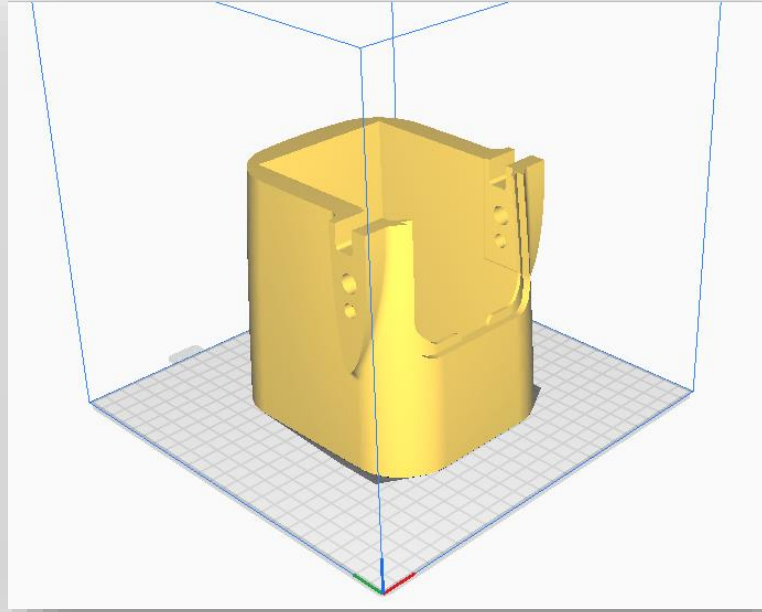

FUS 3 - 3% gyroid infill

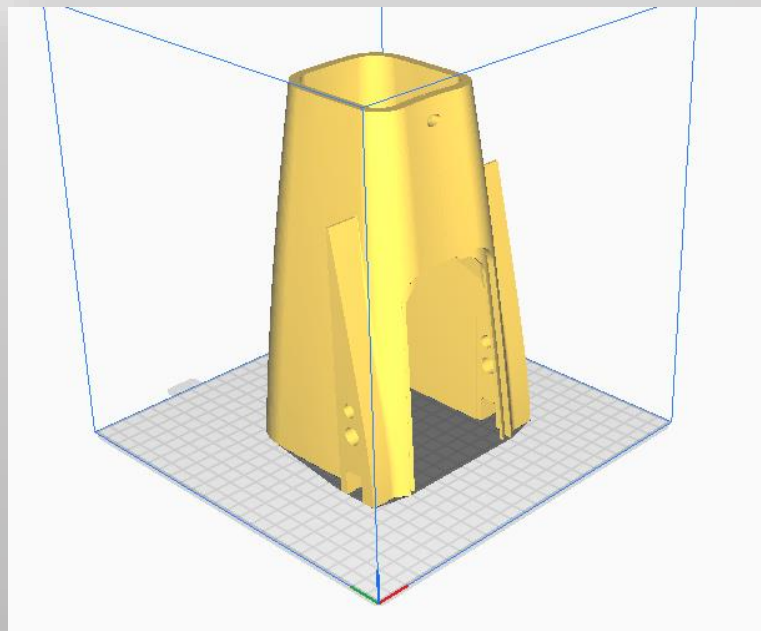

FUS 4 - 3% gyroid infill

# Parts Orientation

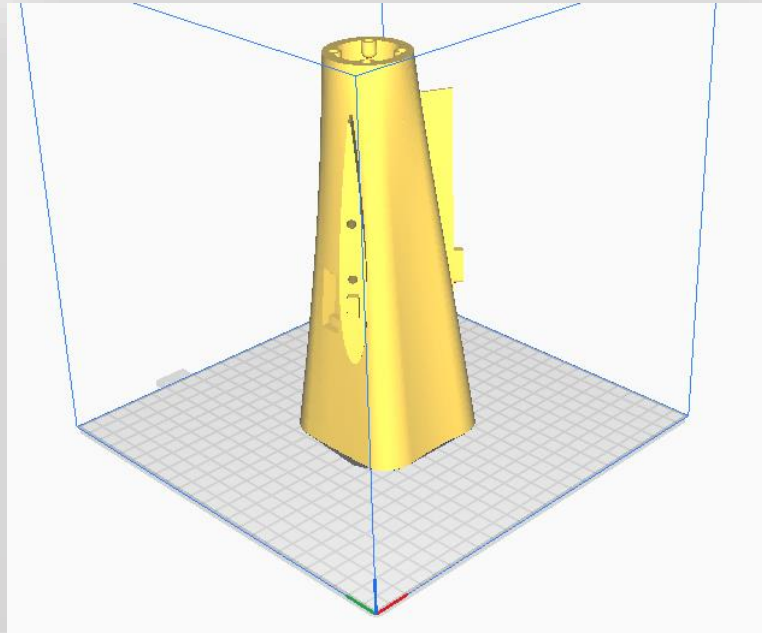

FUS 5 - 3% gyroid infill

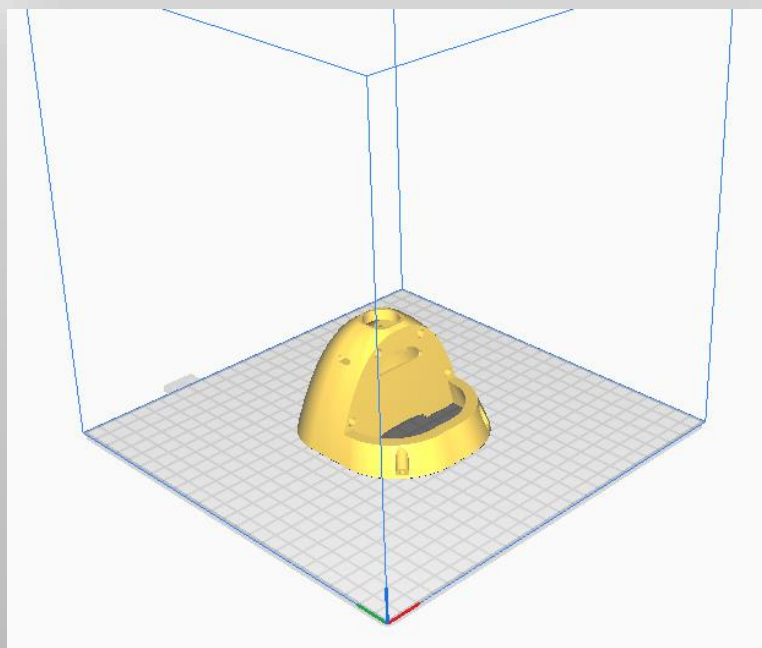

NOSE - 4% gyroid infill + 2 walls



# Parts Orientation

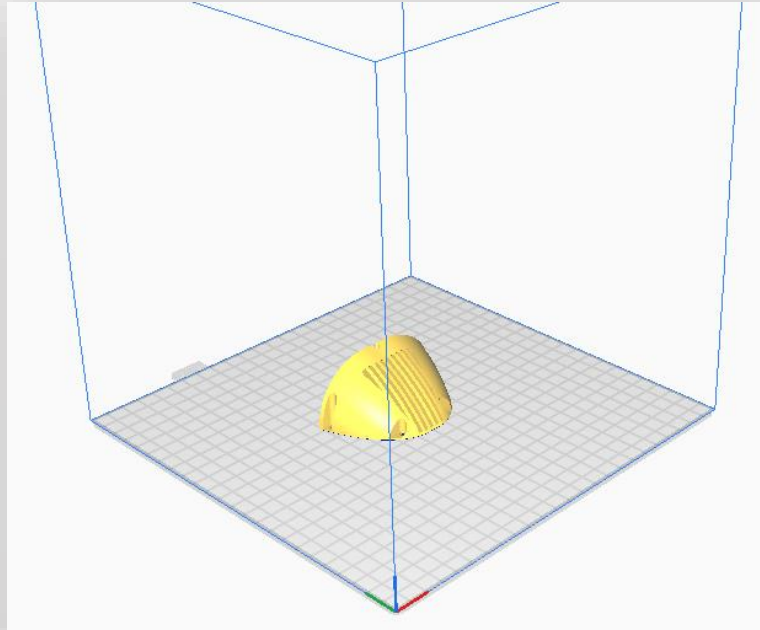

NOSE VTX COVER- 4% gyroid infill + 2 walls

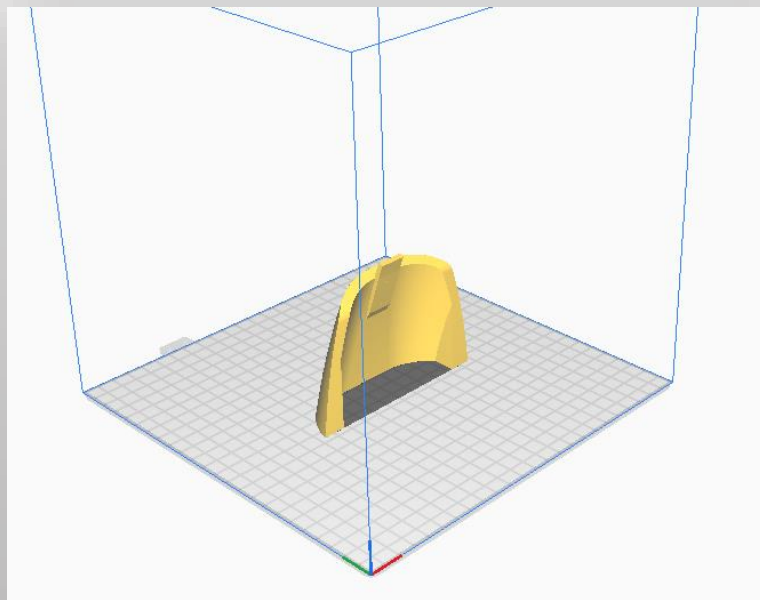

HATCH FRONT 1 - 3% gyroid infill

# Parts Orientation

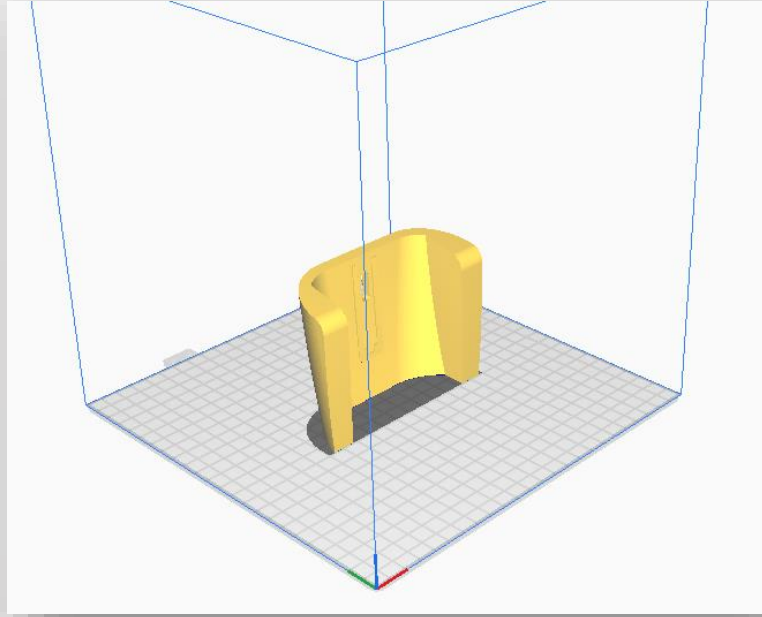

HATCH FRONT 2 - 3% gyroid infill

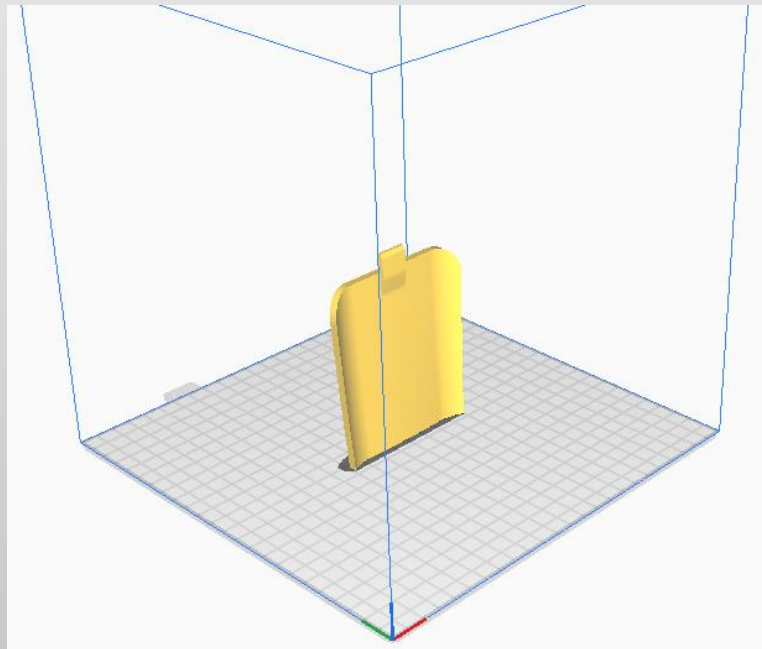

HATCH MIDDLE 1 - 3% gyroid infill

# Parts Orientation

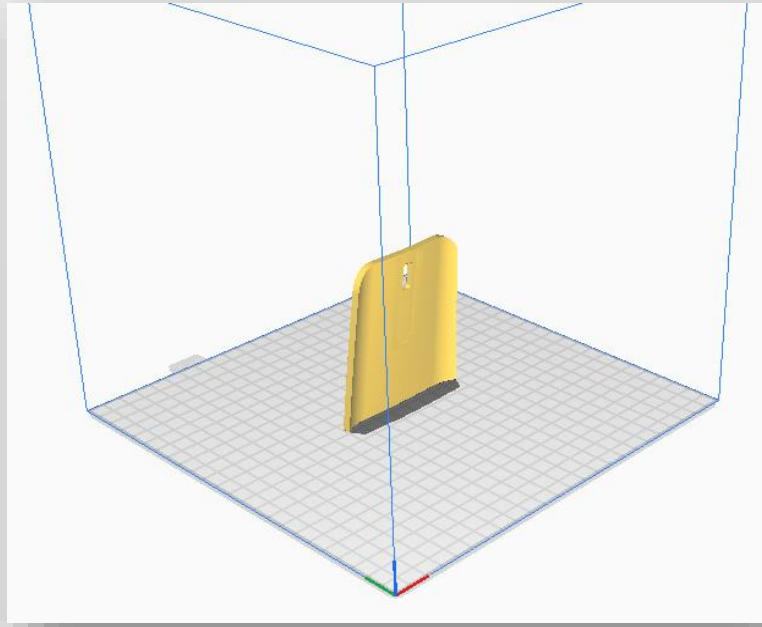

HATCH MIDDLE 2 - 3% gyroid infill

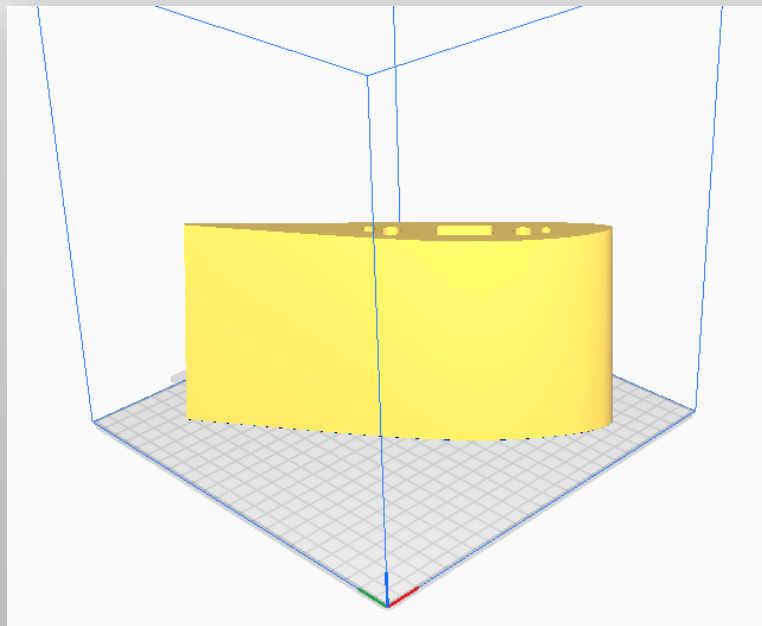

WING 1 - 3% cubic subdivision infill

# Parts Orientation

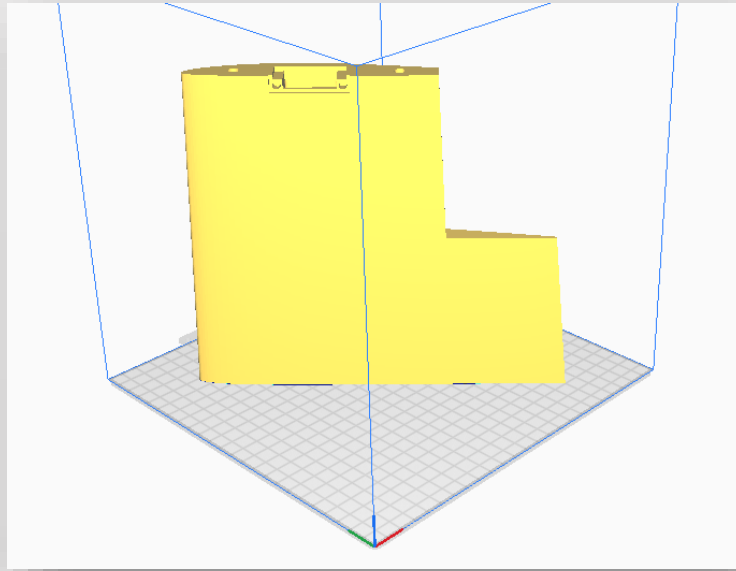

WING 2 - 3% cubic subdivision infill

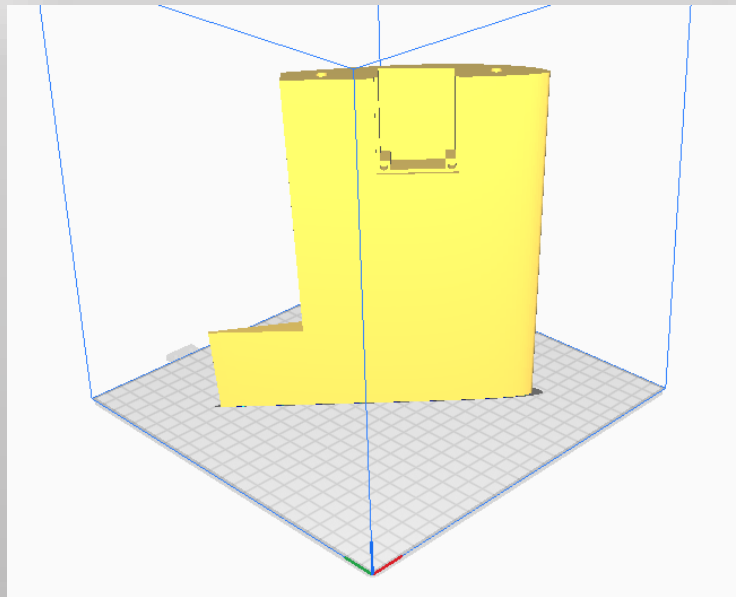

WING 3 - 3% cubic subdivision infill

# Parts Orientation

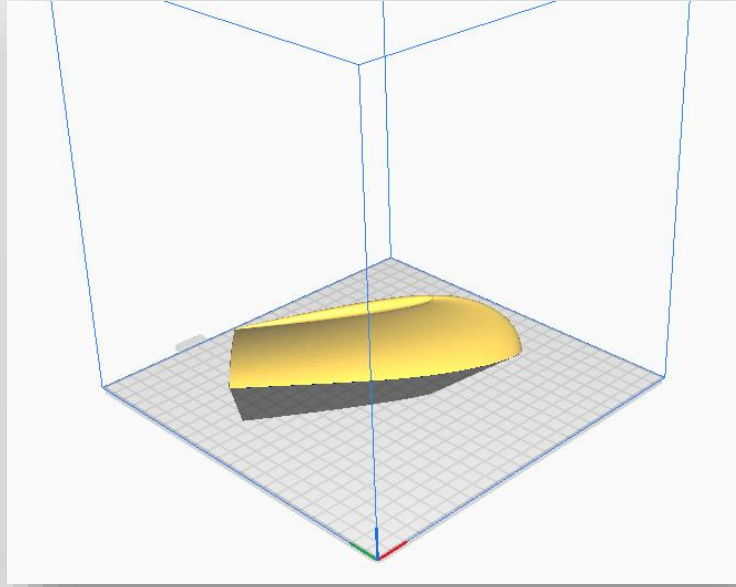

WINGLET- 3% cubic subdivision infill

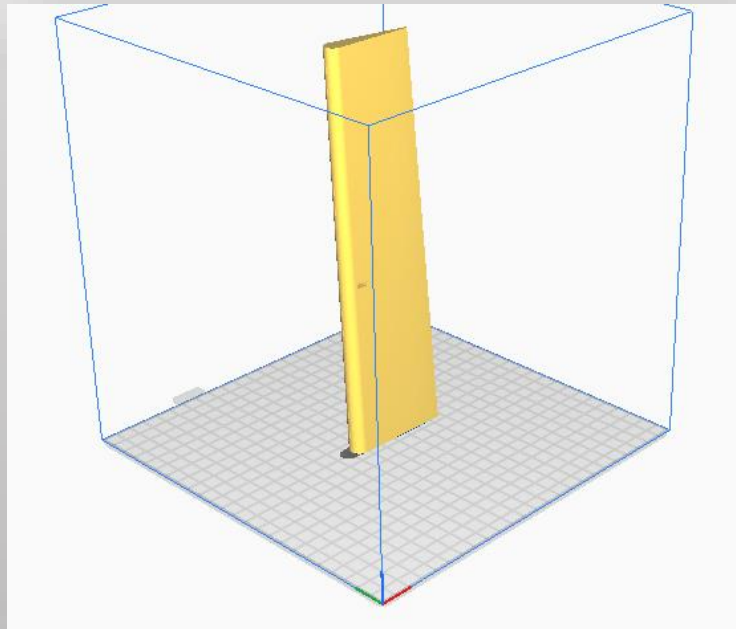

AIL- 4% cubic subdivision infill

# Parts Orientation

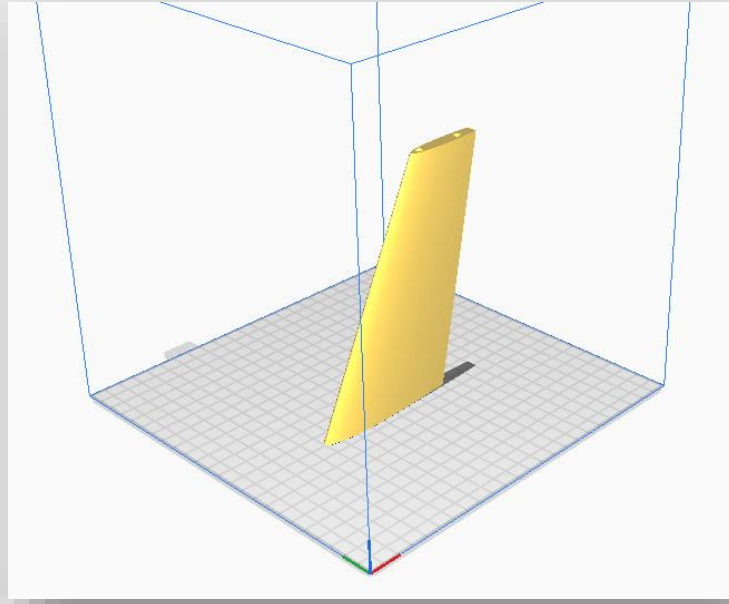

V-TAIL 1 - 3% gyroid infill

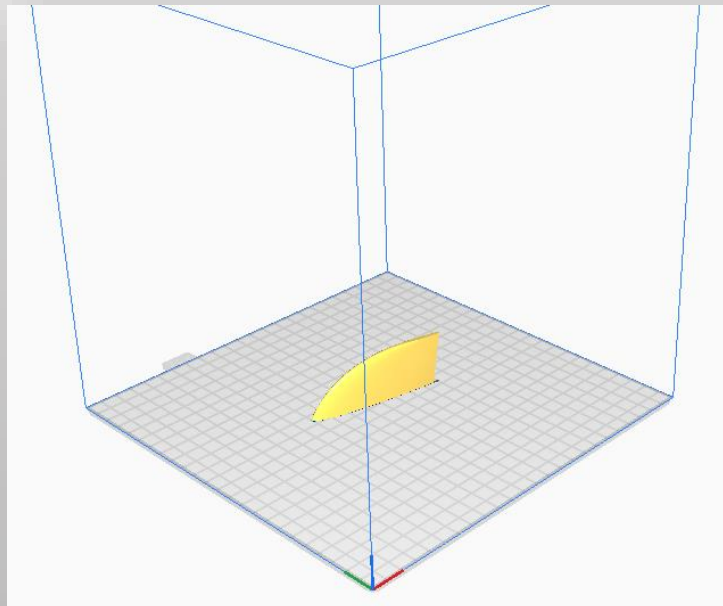

V-TAIL 2 - 3% gyroid infill

# Parts Orientation

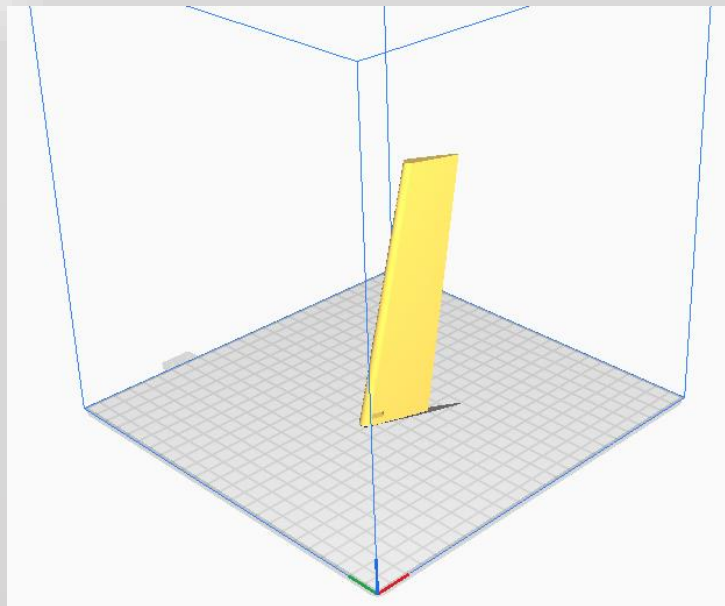

V-TAIL RUDDER - 4% cubic subdivision infill

The other parts are not shown, as they are mainly flat printed parts and their orientation is not in doubt.

# TAIL VARIANTS

Before starting build, choose an option for mounting the motor. There are 2 options to choose from.

The first version is a tail adapter to the 2830 motor or other similar with a mounting bolt spacing of 34mm. Choose then the corresponding version of the **FUS 5** and **FIREWALL** file.

The second option is to use a larger 4108 motor, for which a wider mount is needed. Choose the corresponding **FUS 5** and **FIREWALL** files. An additional **4108 MOTOR MOUNT** part is also prepared for this motor, which you need to print too.

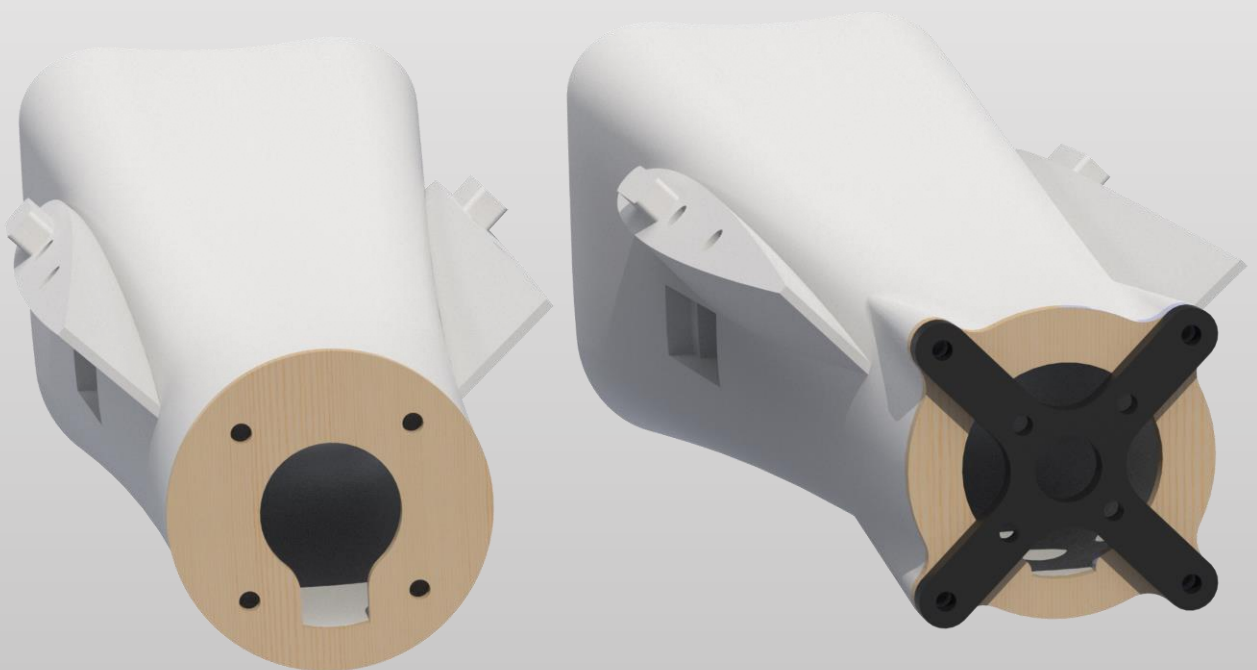



# NOSE VARIANTS

There are also 2 variants of the nose. You can choose version with a VTX mounted inside and a 19x19mm FPV camera, or a clean version with just the FPV camera. The VTX mounts on a "shelf" and the available space is sufficient to accommodate any VTX.

The nose is fully removable, mounted on four M3 screws. It is also available in STEP format for easy editing. You can edit this part and adapt it to your own more individual needs and to mount different payload. You can also have several versions of the nose and change them according to the needs of a particular flight.

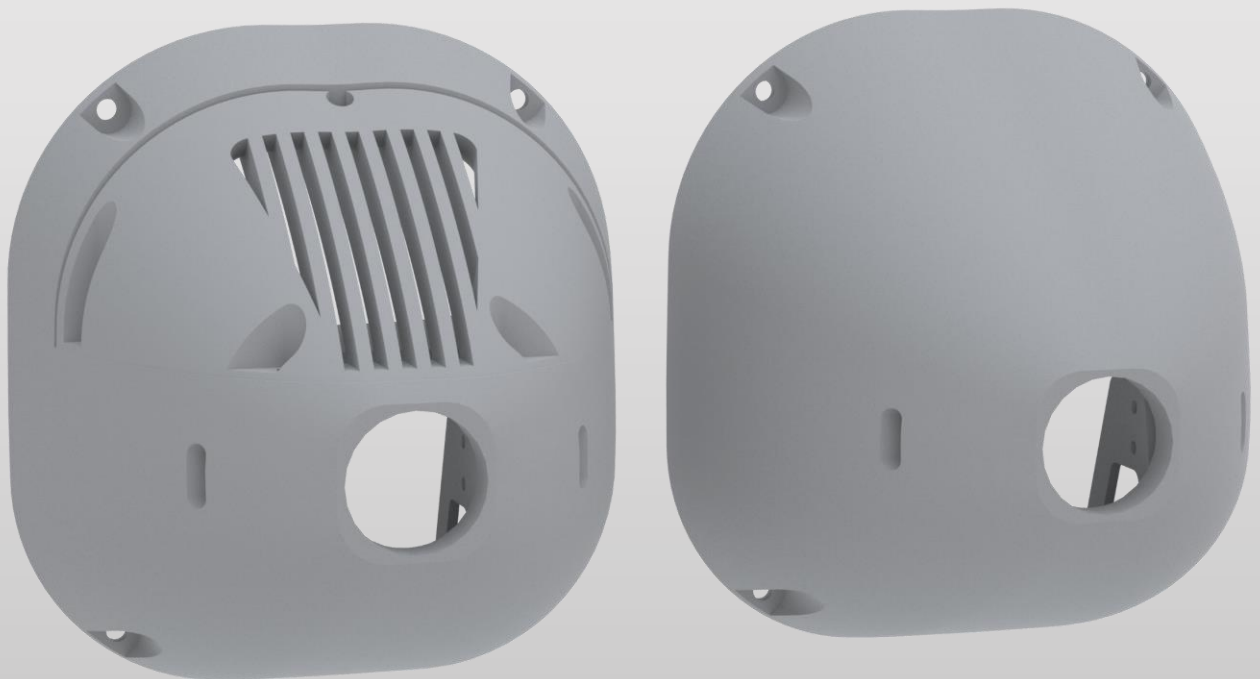

# STEP files

All files are available in STL format. In addition, some important elements are available in STEP format, which allows easier editing and customization.



You can find these files in folders labeled STEP

# Fuselage assembly

Prepare all fuselage segments. Before gluing, you can gently sand the surface of all elements, especially the gluing surfaces.

It's best to use **thick CA glue**.

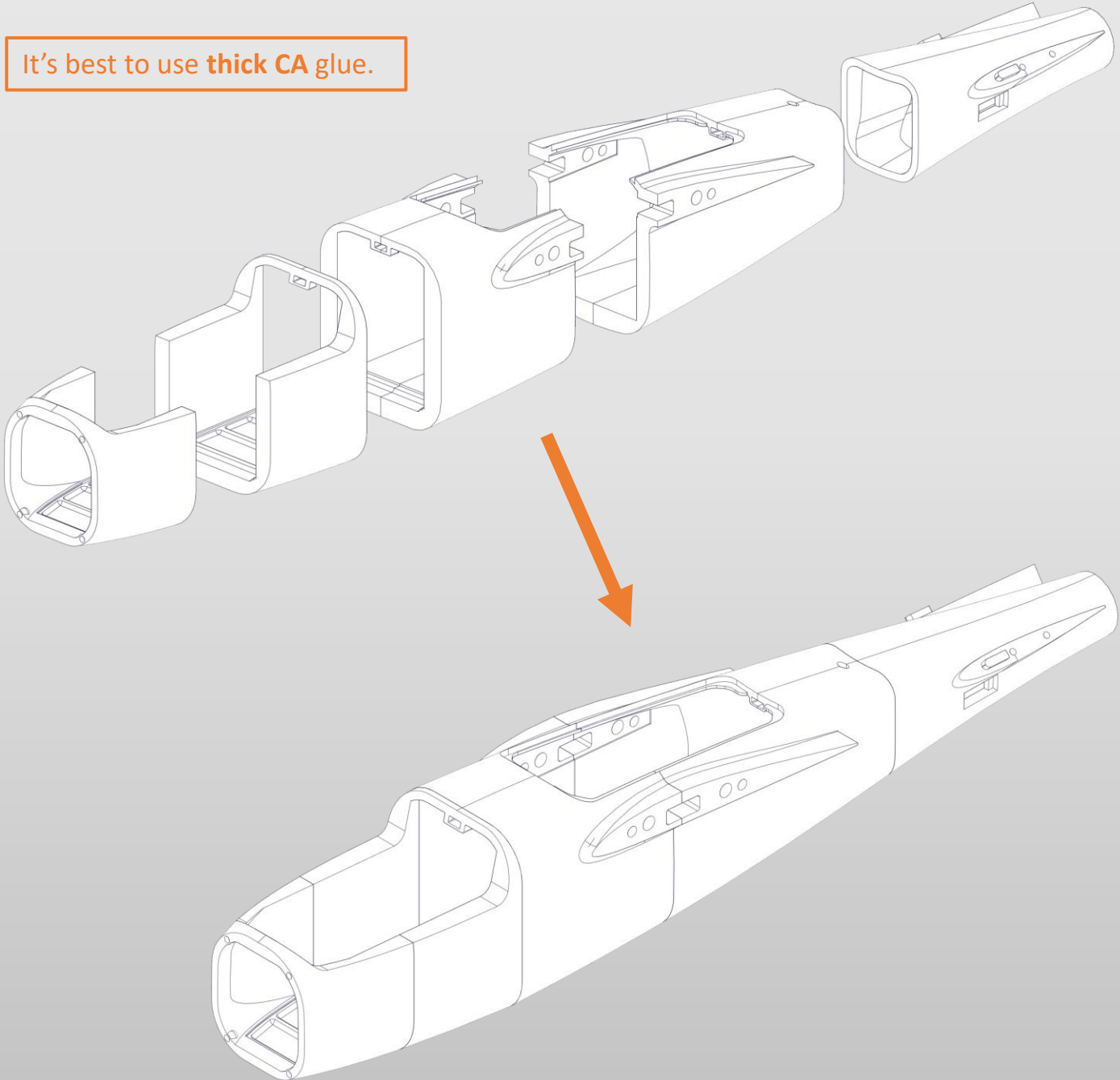

# Fuselage assembly

Prepare parts printed from PLA or other hard material. Take the **BATTERY PAD** and paste it in the designated place in the front of the fuselage.

It's best to use **thick CA glue**.

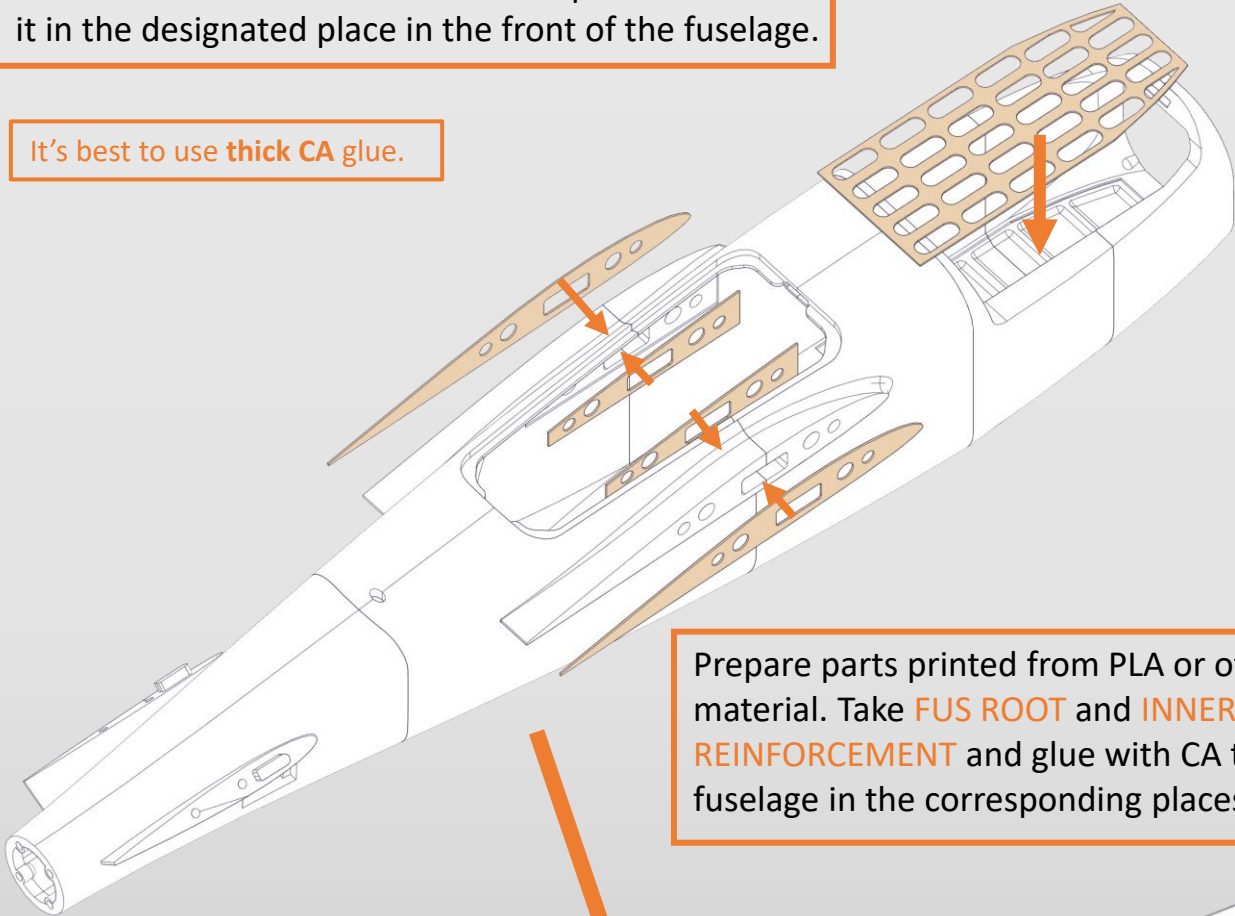

Prepare parts printed from PLA or other hard material. Take **FUS ROOT** and **INNER REINFORCEMENT** and glue with CA to the fuselage in the corresponding places.

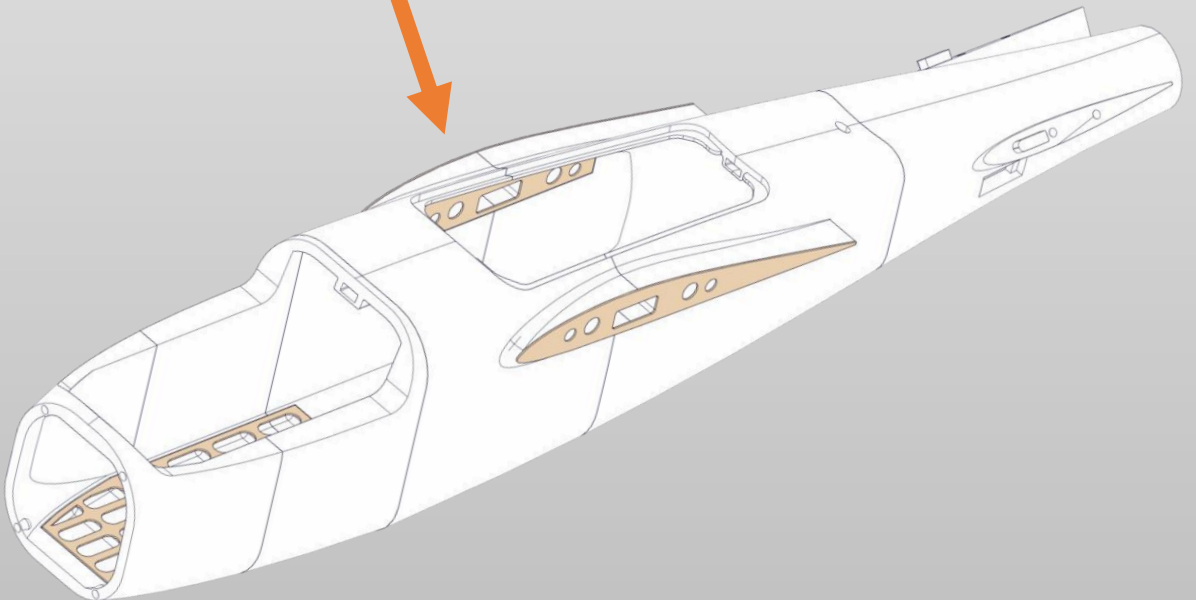

# Fuselage assembly

Now take M3 threaded inserts with an outer diameter of 5mm. Glue them into the designated places in the front part of the fuselage. You can use a slightly heated soldering iron for this. Then glue **NOSE REINFORCEMENT** printed from PLA or other hard material. This noticeably increases the strength of the nose when it is frequently unscrewed and prevents the threaded inserts from being torn out.

It's best to use **thick CA glue**.

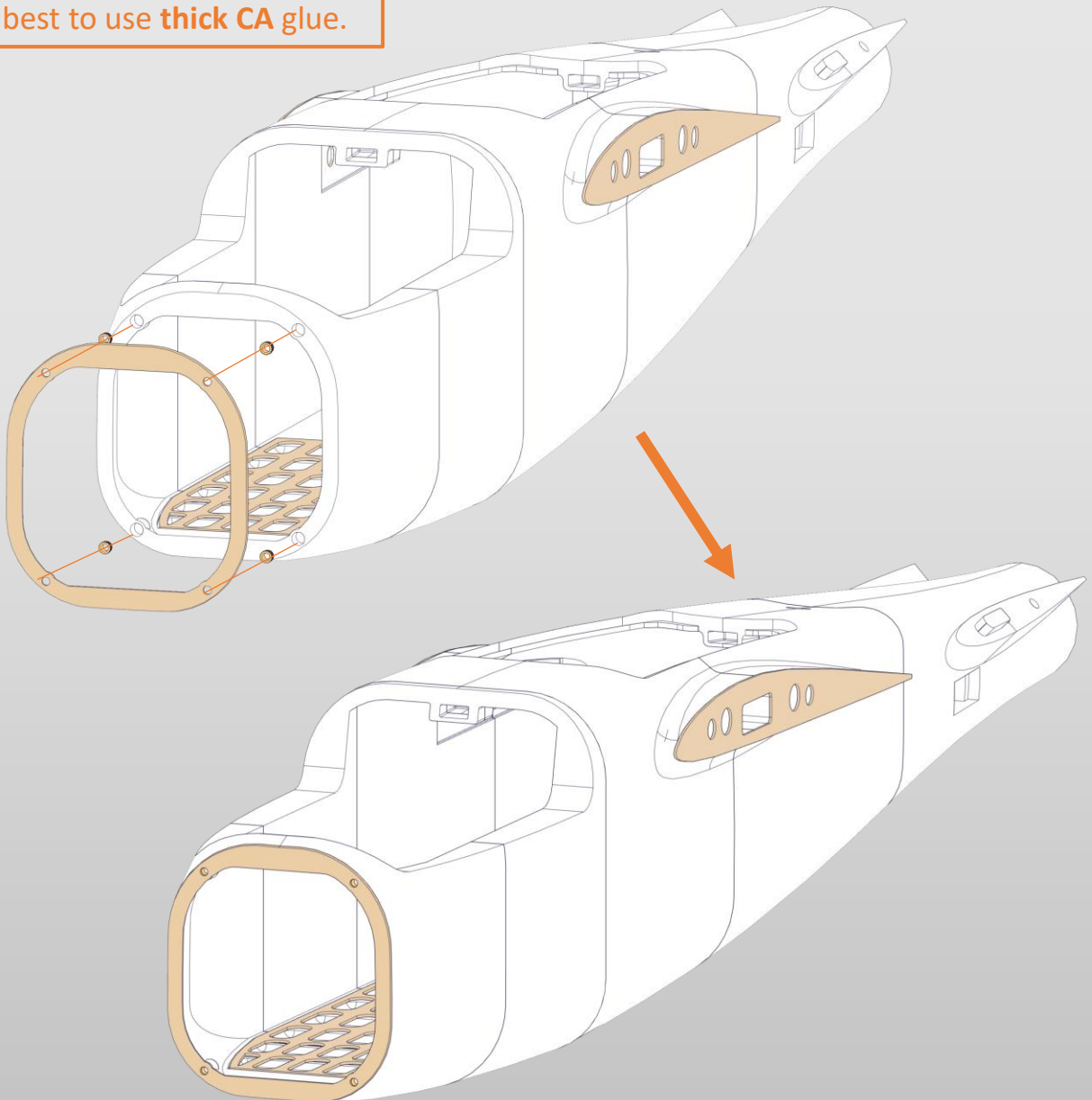

# Hatches

Prepare the front and middle hatch. Both require **LOCK 1** and **LOCK 2**. Assemble the locks by adding a small spring and paste them into the designated places. Glue locks into the hatches using CA, but carefully so that the glue does not spill and block the lock.

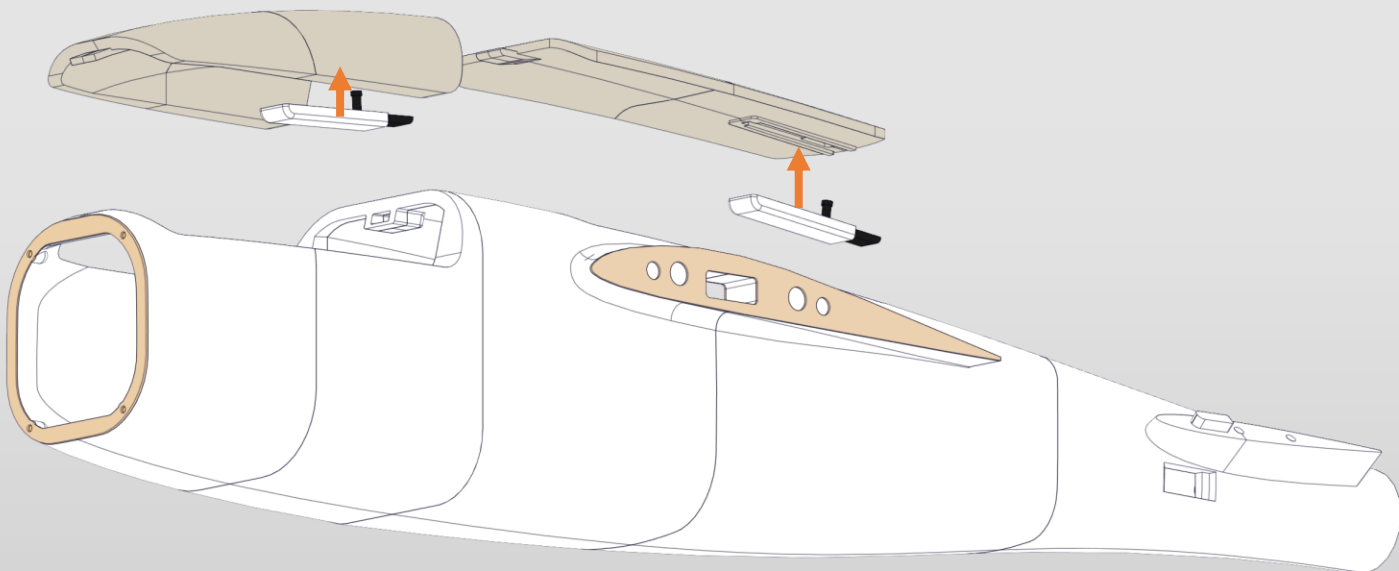

It's best to use **thick CA** glue.

# V-TAIL servos

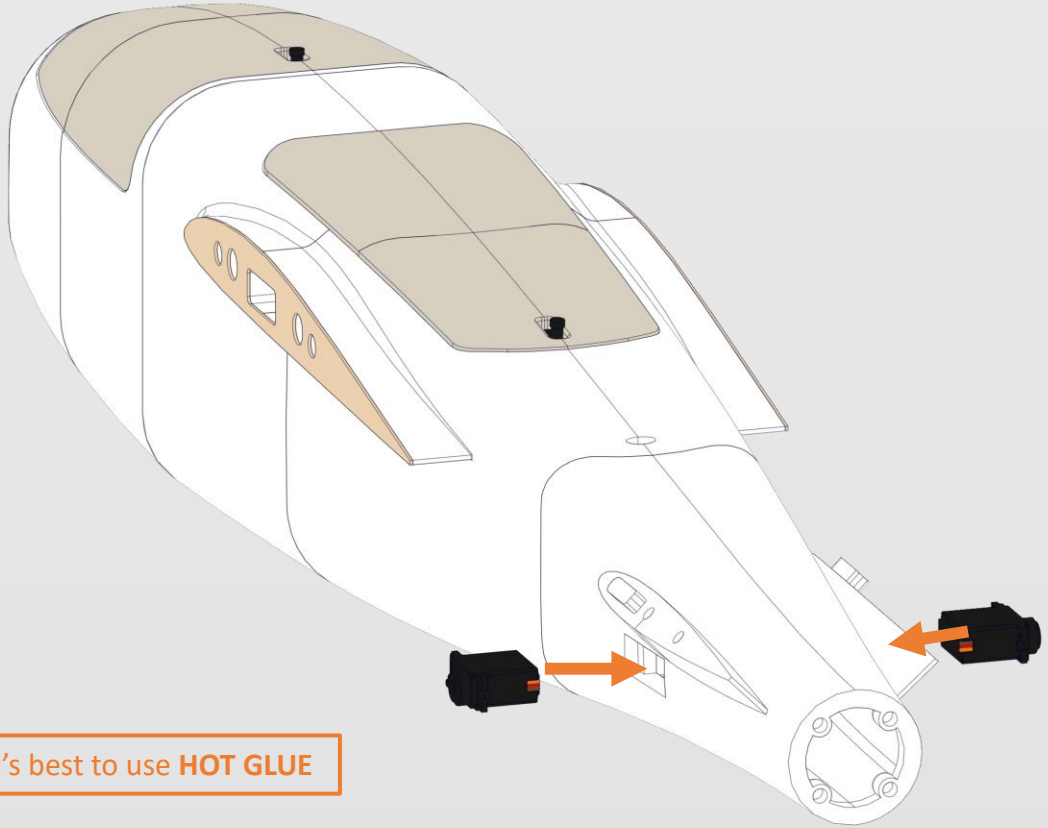

It's best to use **HOT GLUE**

Now insert the V-tail servos into the designated places on the back of the fuselage. Micro servos of standard 9-12g weight will fit. Use a small amount of hot glue to secure them.

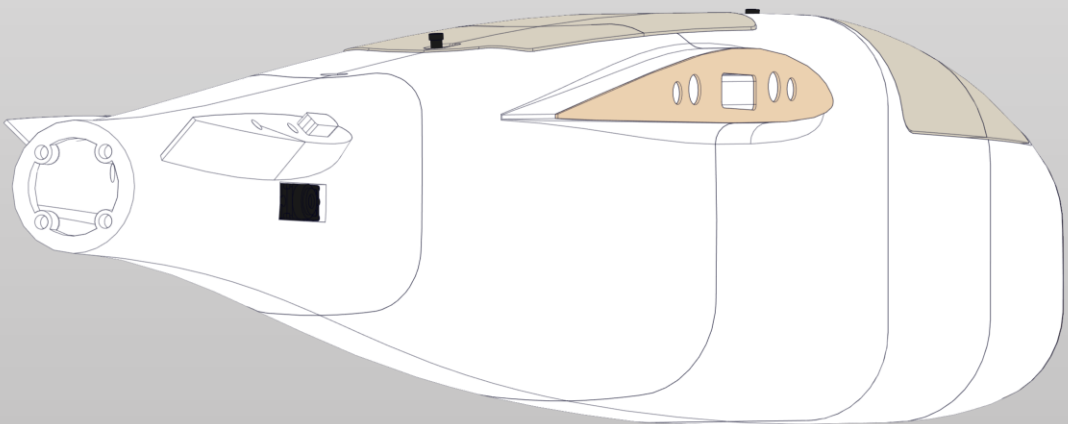

# V-TAIL

Take V tail parts. Glue them together and use 4mm carbon tube cut to 190mm for reinforcement. Use 20x30mm polyester hinges to assemble the rudder by gluing them into the prepared places. Secure them with a drop of thin CA glue. You can also use thin hinges made of other thin materials.

It's best to use **THIN CA** glue.

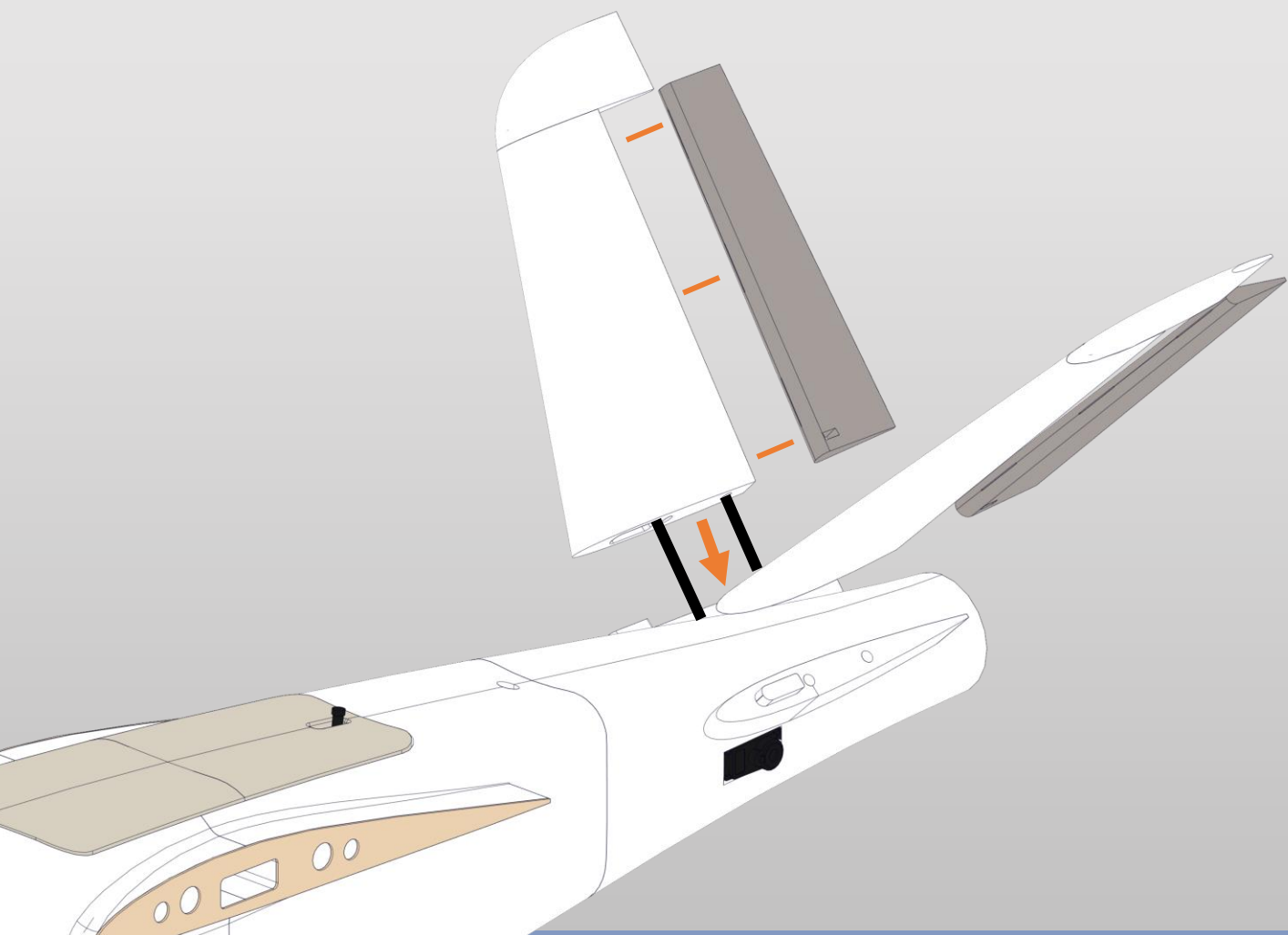



# V-TAIL

Glue the plastic horns into the designated places in the rudders. It is best to do it with thick CA glue. You can make the pushrods yourself using a thin wire and bend it into a Z shape, or use snaps or another pushrod mounting technique.



# Motor mount

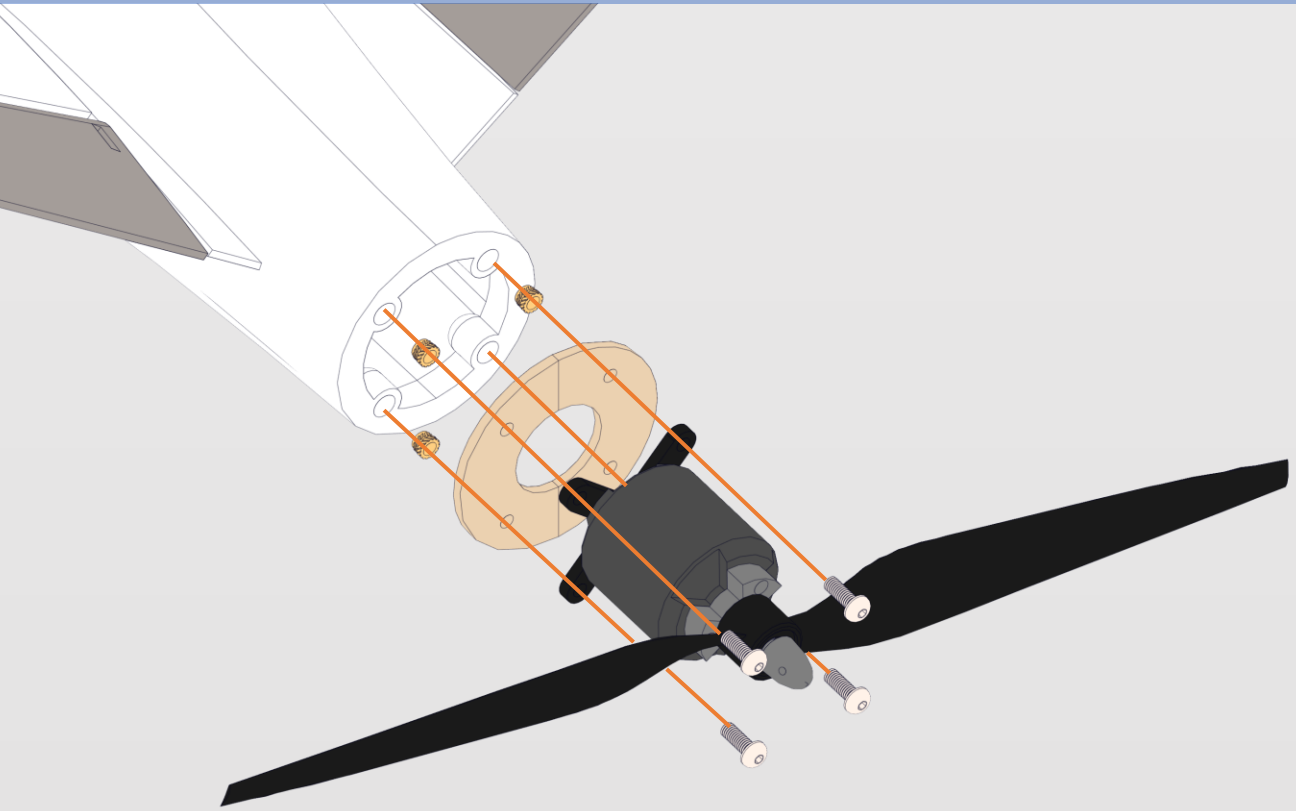

Paste the M3 threaded inserts into the designed places. Then glue the firewall. Finally, screw the motor with M3 screws. The graphic shows the assembly of the 2830 motor. For the 4108 motor, the process looks exactly the same, only the firewall and tail are in slightly different shape.

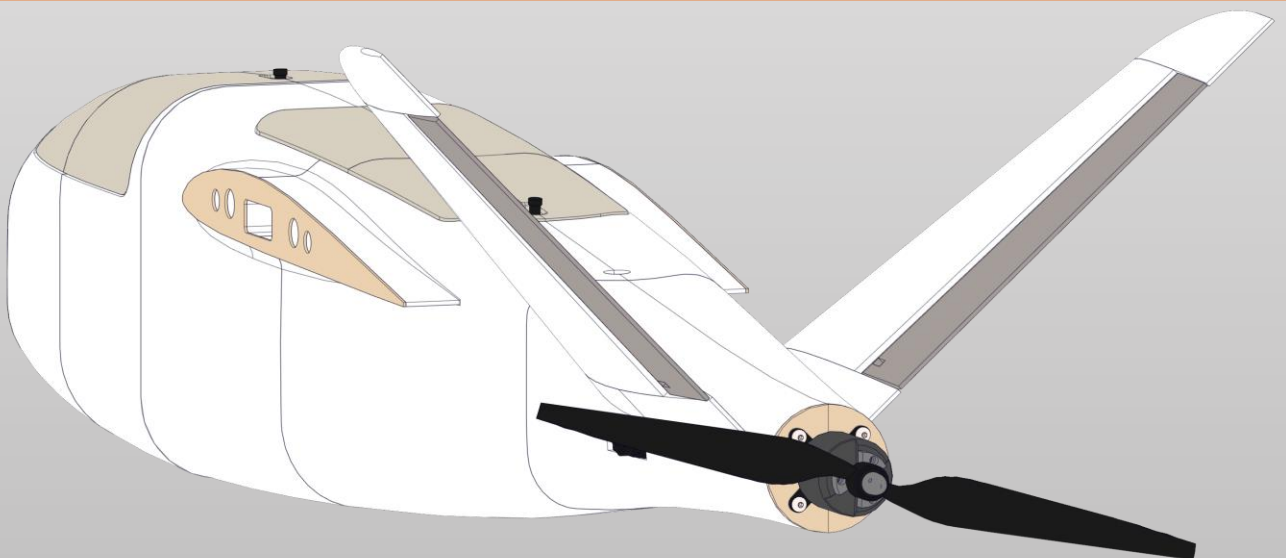

# Nose mount

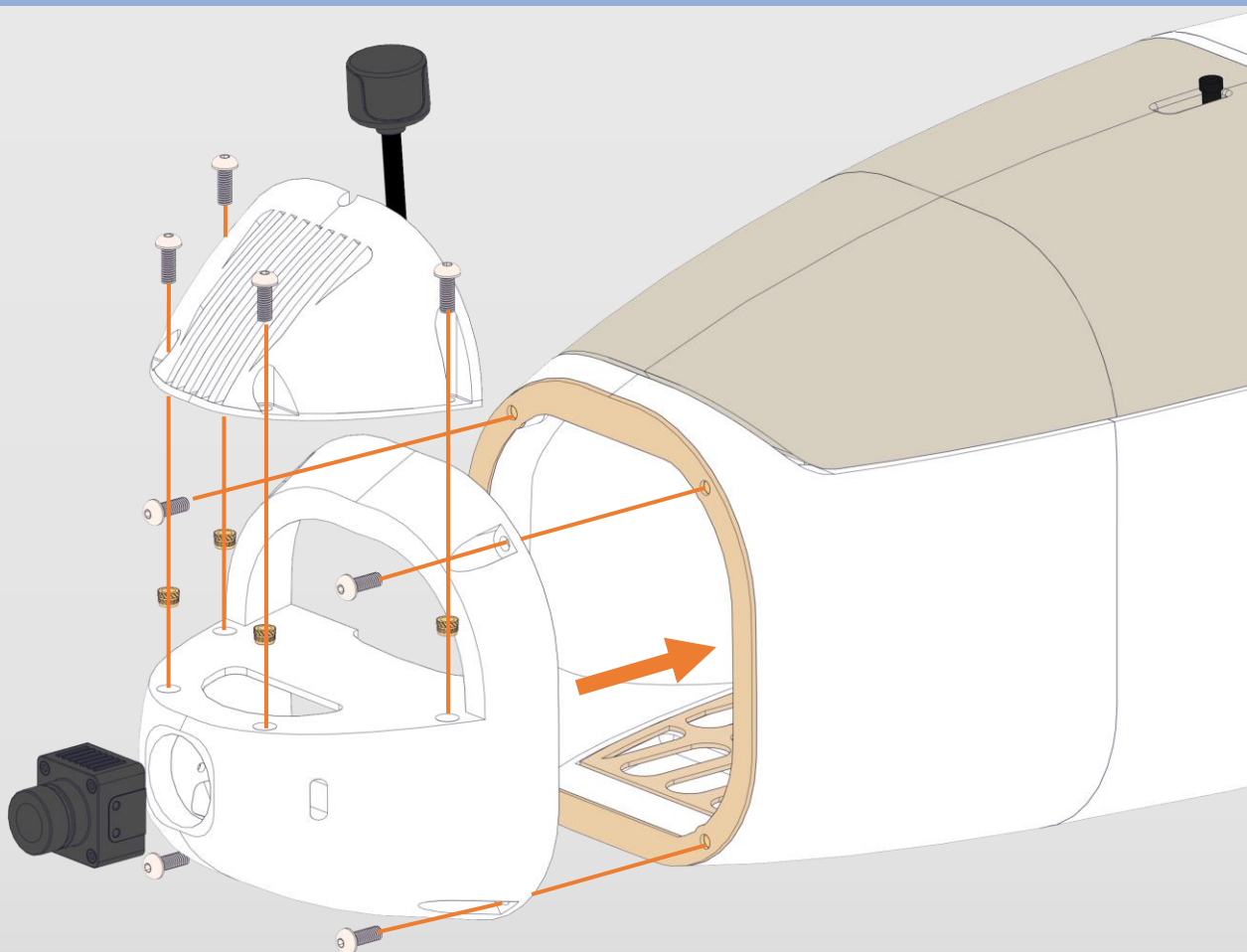

Now you can mount the nose with short M3 screws. If you are using version with VTX, you can put your VTX on the "shelf" and cover it with **NOSE VTX COVER** and secure the antenna.

# Wings assembly

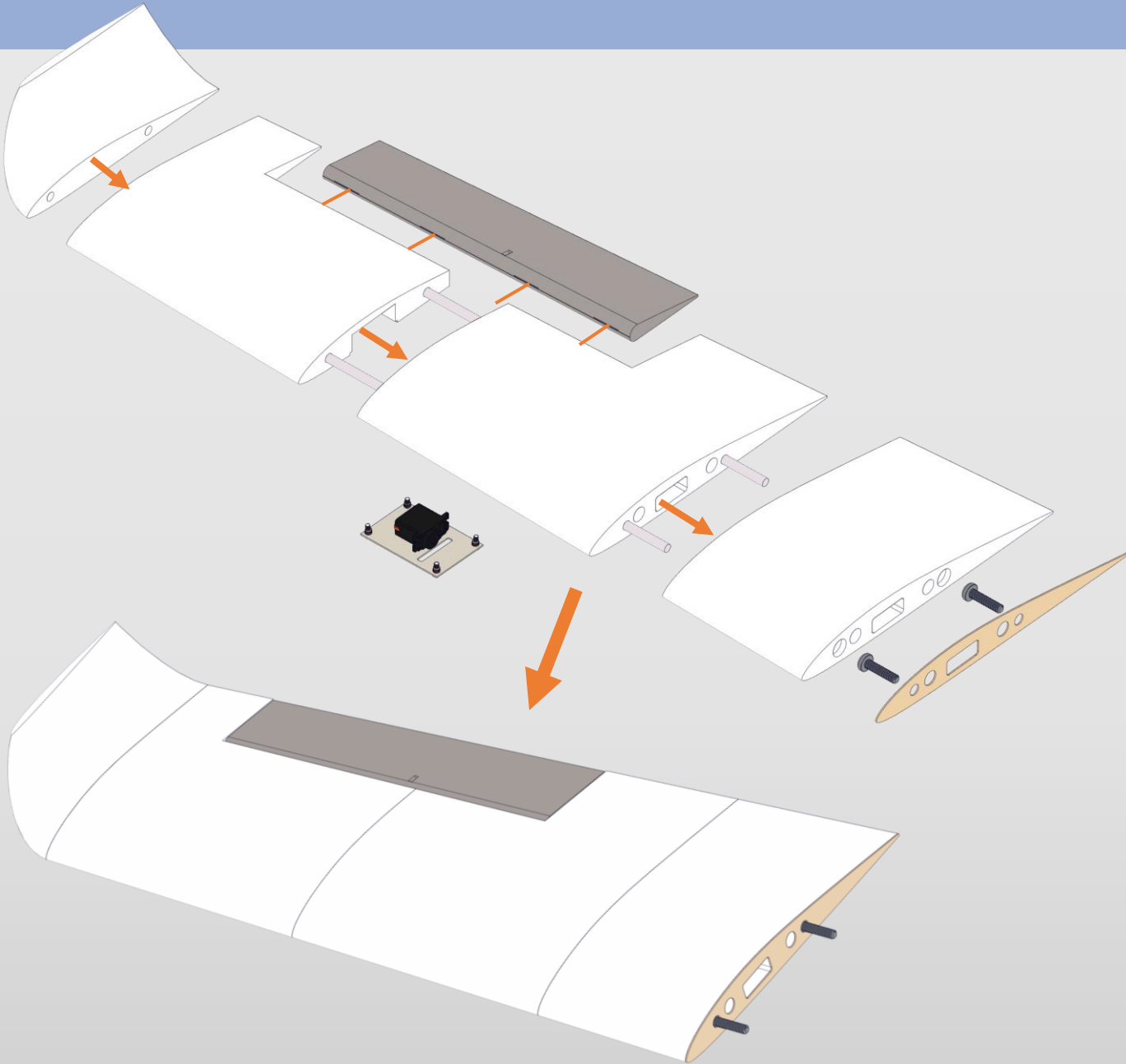

Glue the wing segments together. Insert two 6mm carbon tubes cut to a length of 435mm. It's not necessary to glue the tubes, just press them tightly into the designated holes. Also insert the M6 plastic screws and glue the **ROOT WING**. These screws are responsible for mounting the wing to the fuselage. Finally, insert the aileron using four 20x30mm polyester hinges, or made of another thin material

# Wings assembly

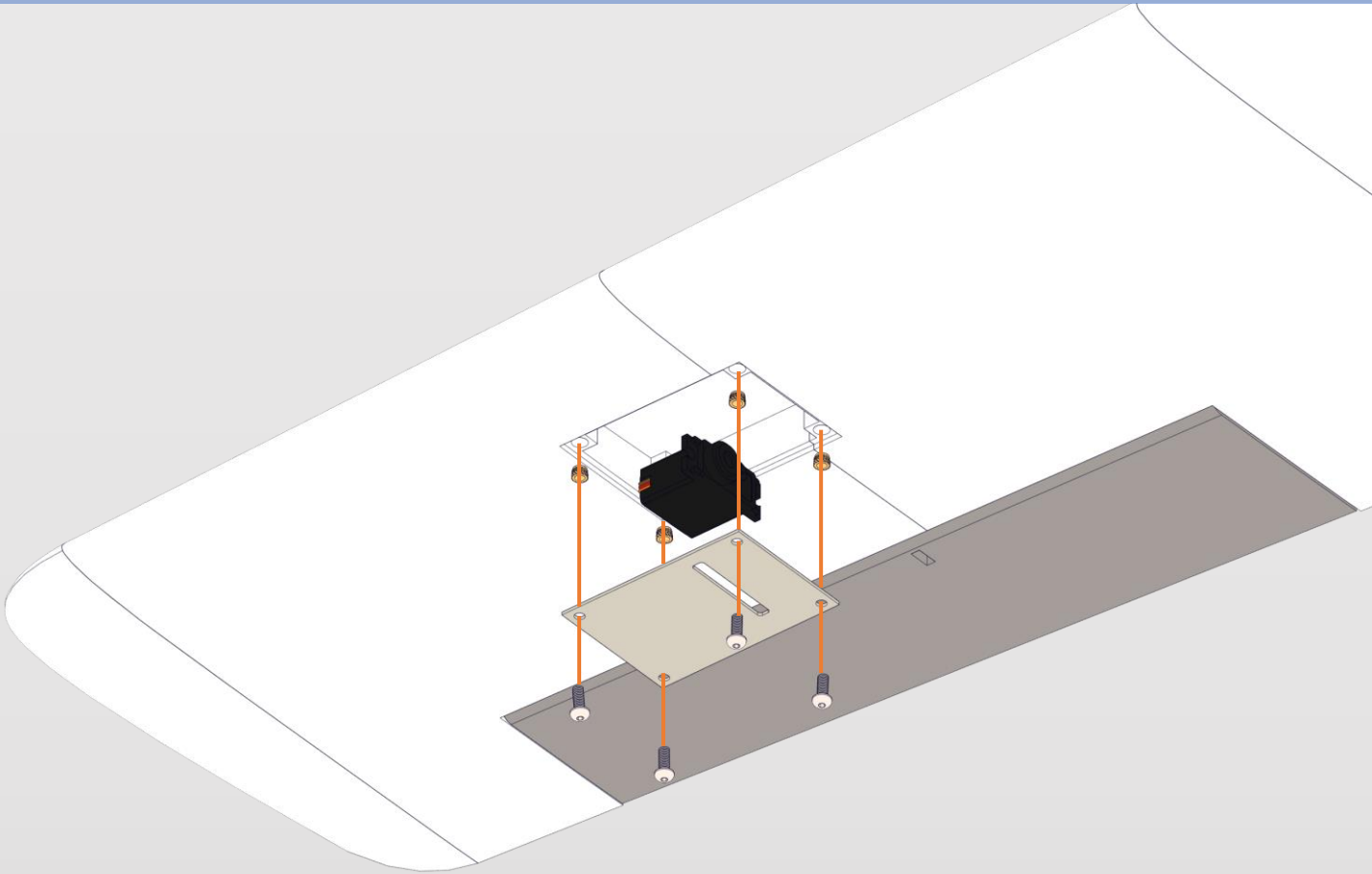

Now mount the servo. Servo bay is spacious and there is no specific position of the servo. You can glue it and secure with hot glue. Use the **SERVO COVER** part so that you place it in the right place and bring the servo arm outward.

Paste the M3 threaded inserts into the designated places and finally cover the servo with **SERVO COVER** fastening it with M3 screws. Then, guide the servo cable through the channel that leads up to the wing root.

# Wings assembly



Finally, paste the aileron horns and fix the pushrods the same way as for the V-Tail. You can bend the wire into a Z shape, or use snaps or other pushrod mounting technique.

# Wings mount

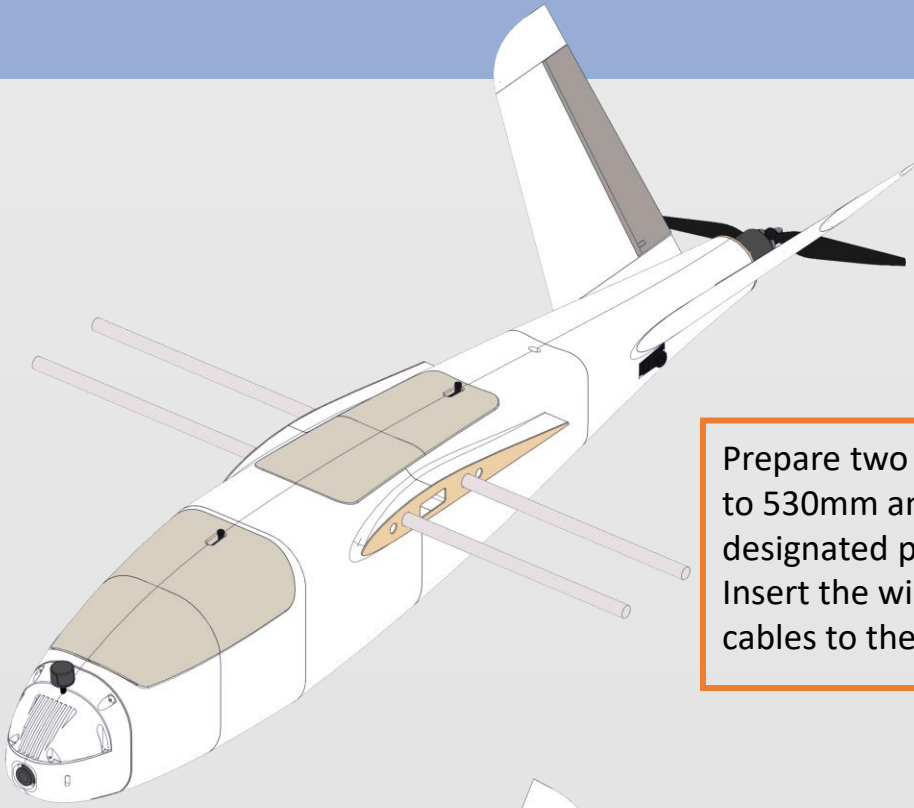

Prepare two 10mm carbon tubes cut to 530mm and insert them into the designated places in the fuselage. Insert the wings, then lead the servo cables to the center of the fuselage

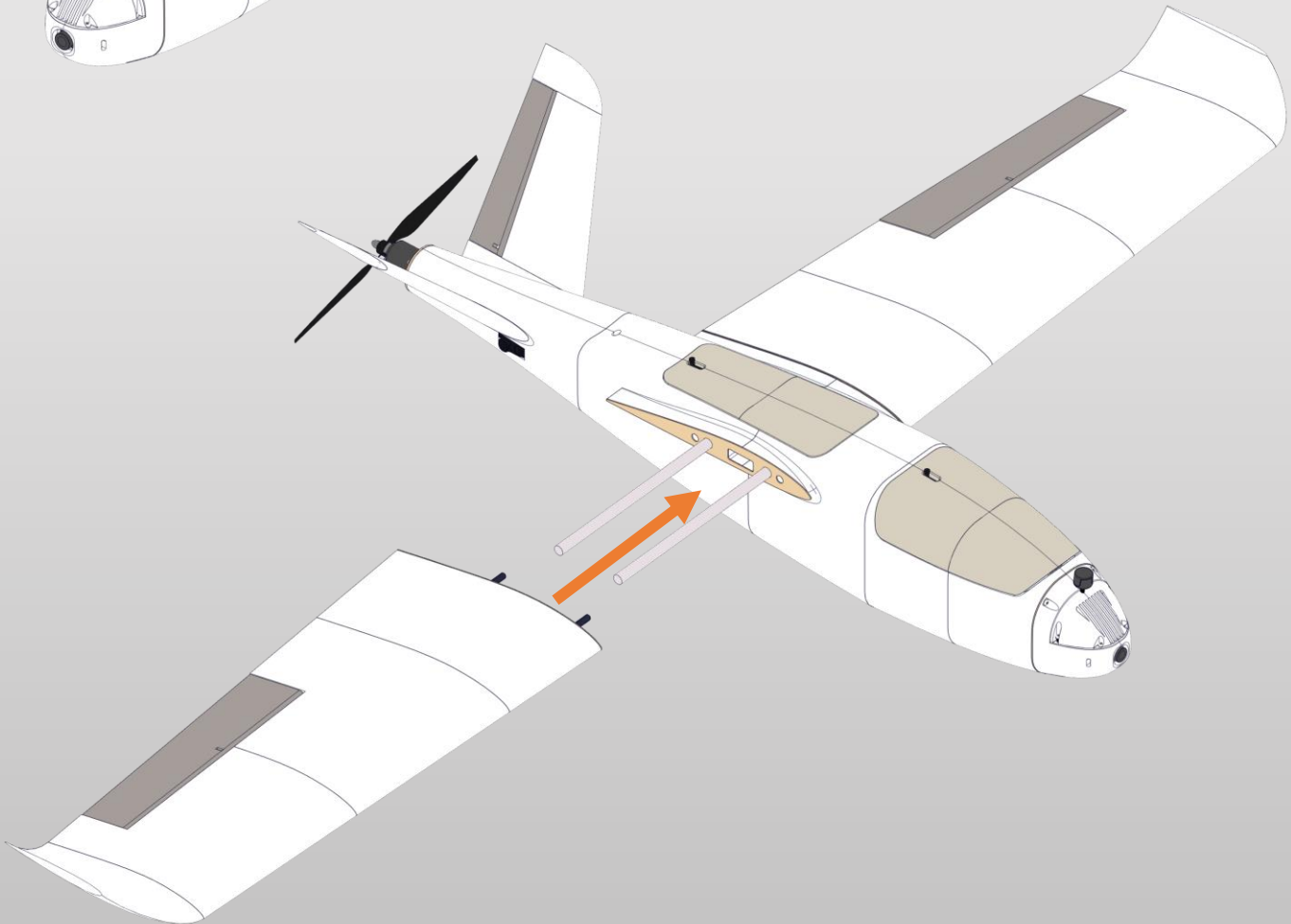

# Wings mount

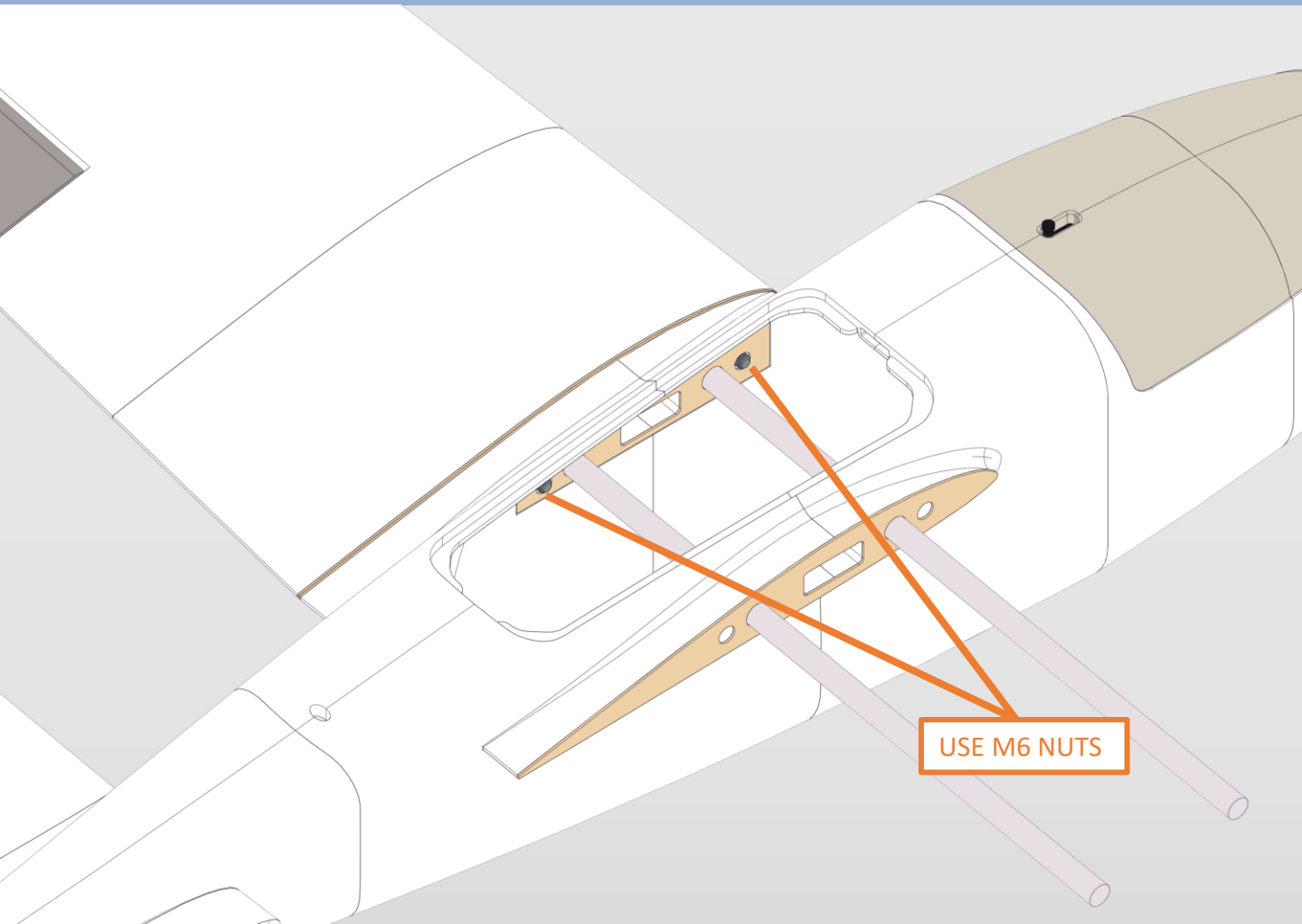

Secure the M6 screws with nuts from inside the fuselage. You can use any M6 nuts that you can manage to screw on by hand. It is best to use plastic nuts that match the plastic screws because of the lower weight. This method of fastening is durable, secure and resistant to repeated disassembly of the wings.



# Equipment layout

The fuselage of the aircraft is very spacious. The front part of the fuselage will accommodate a very large battery even Li-Ion 4S6P 21Ah pack. The **BATTERY PAD** is designed so that Velcro straps can be inserted between the holes to tighten the battery. The central part, accessed through the middle hatch, is designed to accommodate the rest of the equipment such as flight controller, receiver etc. There is an large flat surface that will fit everything you need. You can also place the GPS there next to the FC, or bring it outside the fuselage. There is a small hole in the back through which you can run the cables from the GPS. You can place the ESC inside the fuselage slightly behind the wings.

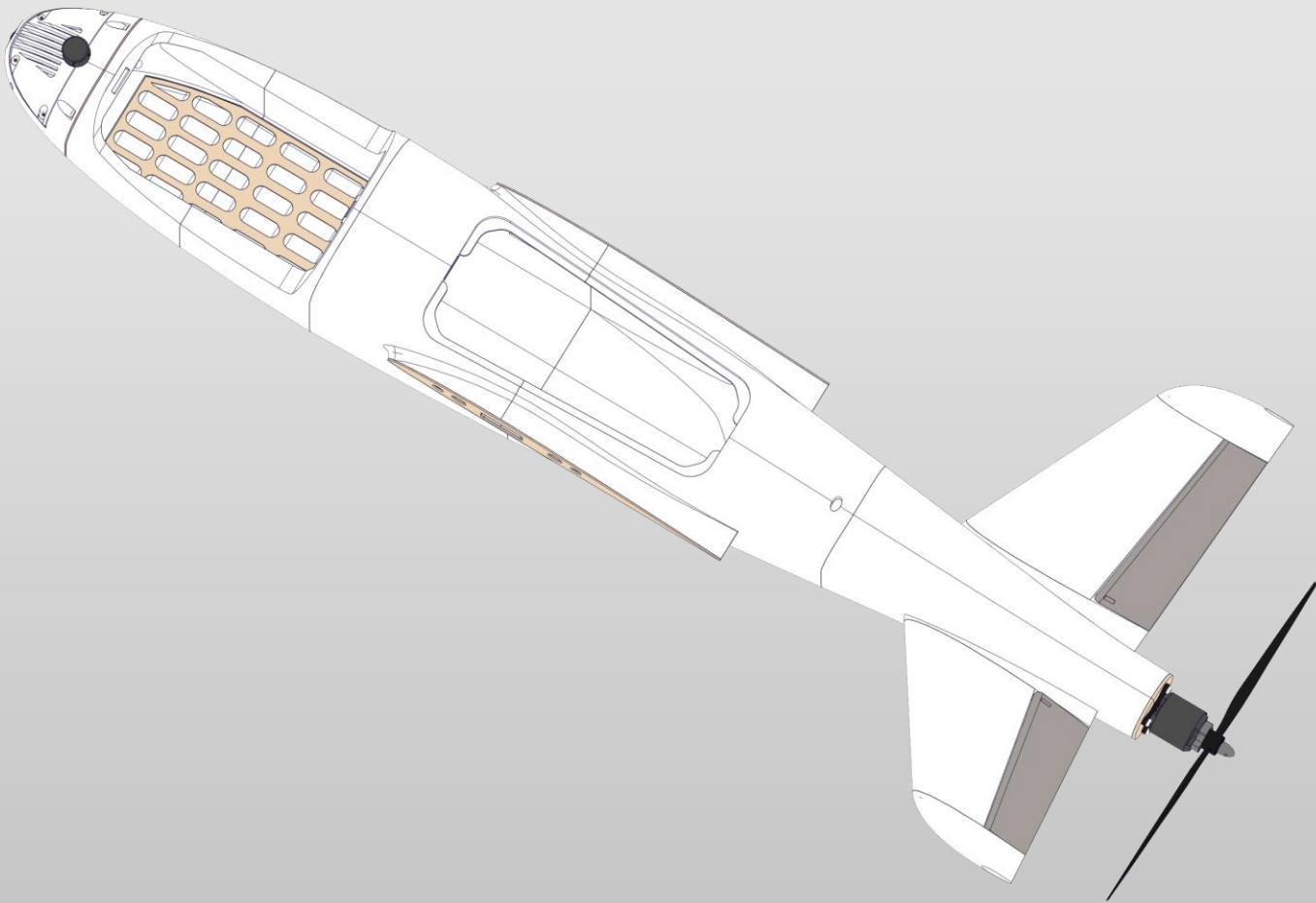

# Finishing build

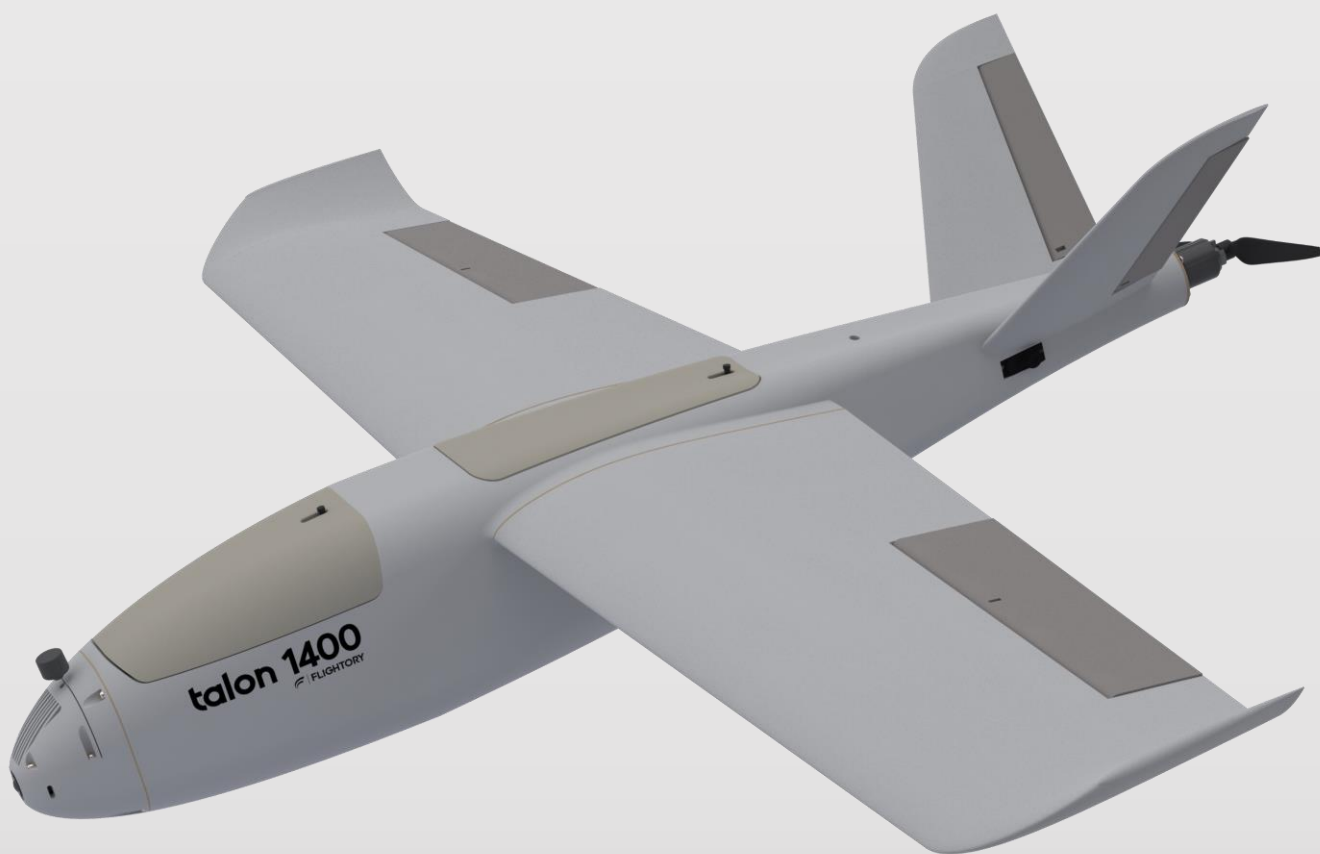

The model is ready to fly. Before flying, take care of the correct balance, which is 65mm from the leading edge. Check the correct operation of the ailerons and rudders and the direction of propeller rotation. The takeoff is done by hand throw. Grab the fuselage under the wings and throw it in a confident motion at a slight angle of attack. Good luck with your flights!

# talon 1400

